

PIXUS iP3100 / iP4100

PIXMA iP4000

PARTS CATALOG

REVISION 0

9316A012AA	iP3100/ 100V(JP)
9317A001AA	iP4000/ 120V(US)
9317A002AA	iP4000/ 120V(CA)
9317A005AA	iP4000/ 220V-240V(EUR)
9317A008AA	iP4000/ 220V-240V(ASA HVT)
9317A009AA	iP4000/ 220V-240V(AU)
9317A010AA	iP4000/ 220V-240V(KR)
9317A011AA	iP4000/ 220V-240V(GB)
9317A012AA	iP4100/ 100V(JP)
9317A013AA	iP4000/ 120V(TW)
9317A014AA	iP4000/ 220V-240V(HK)
9317A015AA	iP4000/ 220V-240V(CN)
9317A017AA	iP4000/ 220V-240V(EUM)



JULY 2004

QY8-31C3-000

COPYRIGHT © 2004 CANON INC. CANON PIXUS iP3100/iP4100/PIXMA iP4000 0704 N 0.00-0

Application

This manual has been issued by Canon Inc. for qualified person to learn technical theory, installation, maintenance, and repair of products. This manual covers all localities where the products are sold. For this reason, there may be information in this manual that does not apply to your locality.

Corrections

This manual could include technical inaccuracies or typographical errors due to improvements or changes in the products. When changes occur in applicable products or in the content of this manual, Canon will release technical information as the need arises. In the event of major changes in the contents of this manual over a long or short period. Canon will issue a new editions of this manual. The following paragraph does not apply to any countries where such provisions are inconsistent with local law.

Trademarks

The product names and company names described in this manual are the registered trademarks of the individual companies.

Copyright

This manual is copyrighted with all rights reserved. Under the copyright laws, this manual may not be copied, reproduced or translated into another language, in whole or in part, without the written consent of Canon Inc.

Copyright © 2004 by Canon Inc.

CANON INC.

Inkjet SFP Quality Assurance Div.

16-1, Shimonoge 3-chome, Takatsu-ku, Kawasaki-shi, Kanagawa 213-8512, Japan

This manual was created under Microsoft® Windows® 2000.

Parts layout pictures were edited using Adobe® Photoshop® 7.0. KEY No. were created using Adobe® Illustrator® 10.

HTML files were created using Microsoft® FrontPage® 2000.

ABOUT THIS MANUAL

A. ILLUSTRATION INDEX

For illustration index, the parts layout illustrations in this parts catalog are listed in abbreviated form in order of illustration number to identify the pages they appear on. To find an illustration of a part, see the ILLUSTRATION INDEX.

B. PARTS LAYOUT & PARTS LIST

Parts layout illustration

a) Parts search

Find a part from the parts layout illustration and find its key number from the parts list to identify the part number and name. For screws, nuts, washers, lock washers, pins, spacers, see SCREWS & WASHERS LIST.

Note: If parts have the same or similar shape but different specifications, their key number is assigned to several part numbers and names in the parts list.

b) Parts replacement procedure

To replace parts, the parts layout illustrations have figure numbers according to the disassembly procedure of the product. The parts that require careful work are shown the illustration.

Parts list

a) FIGURE & KEY No.

The FIGURE & KEY No. column corresponds to the key numbers assigned to the parts in the parts layout illustration.

b) PART NUMBER

The PART NUMBER column gives the part numbers corresponding to the key numbers. To order a part, indicate the part number clearly.

Note: Parts marked NPN are not service parts.

c) RANK

The service parts with N in the RANK column are order parts.

d) QTY

The QTY column gives the number of parts in the corresponding components layout illustration.

e) DESCRIPTION

The DESCRIPTION column gives the part names in English.

To order a part, indicate the part name, too.

C. OPTIONS & CONSUMABLES

These are illustrations and a list of units that can be used as optional consumable equipments.

D. SCREWS & WASHERS LIST

This is a list of screws, nuts, washers, lock washers, pins, and spacers.

The QTY column does not give the number of parts used.

E. TOOL LIST

This is a list of tools used for servicing products.

F. NUMERICAL INDEX

All the parts listed in this parts catalog are arranged in order of part number. You can identify part locations and names from the NUMERICAL INDEX.

Contents

A. ILLUSTRATION INDEX ▶

B. PARTS LAYOUT & PARTS LIST

[FIGURE 1 PRINTER & CASSETTE & PRINT HEAD](#)

[FIGURE 2 AC ADAPTER](#)

[FIGURE 3 OPERATION PANEL UNIT & MAIN CASE UNIT](#)

[FIGURE 4 BOTTOM CASE UNIT](#)

[FIGURE 5 LOGIC BOARD](#)

[FIGURE 6 SHEET FEED UNIT](#)

[FIGURE 7 INK ABSORBER](#)

[FIGURE 8 CARRIAGE UNIT](#)

[FIGURE 9 PURGE UNIT](#)

[FIGURE 10 PLATEN UNIT](#)

[FIGURE 11 PAPER FEED & CARRIAGE LIFT PART \(PIXUS iP3100\)](#)

[FIGURE 12 PAPER FEED & CARRIAGE LIFT PART \(PIXMA iP4000/PIXUS iP4100\)](#)

C. OPTION & CONSUMABLES ▶

D. SCREW & WASHER LIST ▶

E. TOOL ▶

F. NUMERICAL INDEX ▶

A. ILLUSTRATION INDEX

Contents

FIGURE 1 PRINTER & CASSETTE & PRINT HEAD

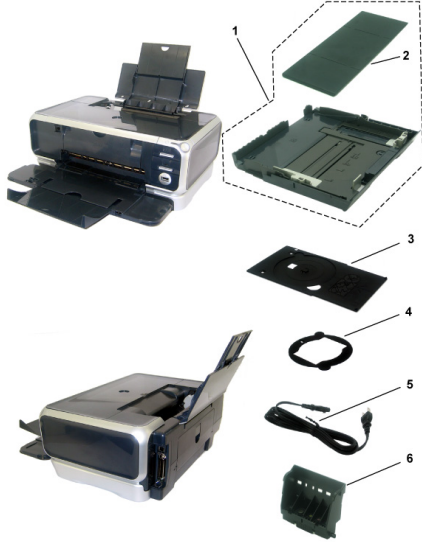

FIGURE 2 AC ADAPTER

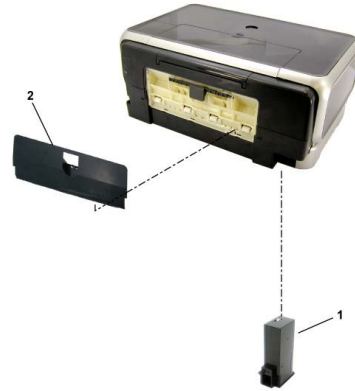

FIGURE 3 OPERATION PANEL UNIT & MAIN CASE UNIT

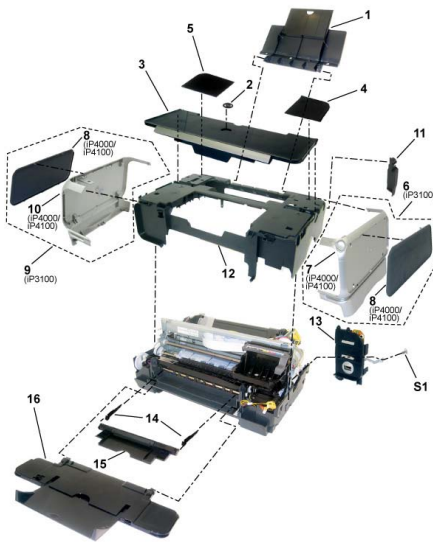

FIGURE 4 BOTTOM CASE UNIT

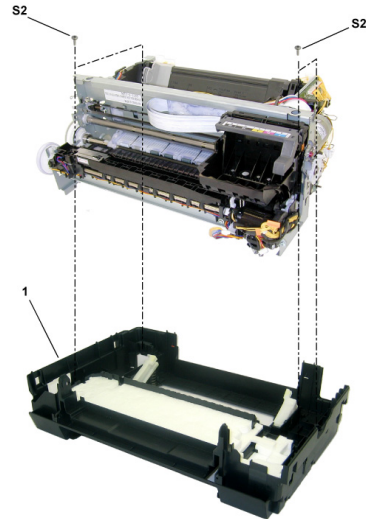

FIGURE 5 LOGIC BOARD

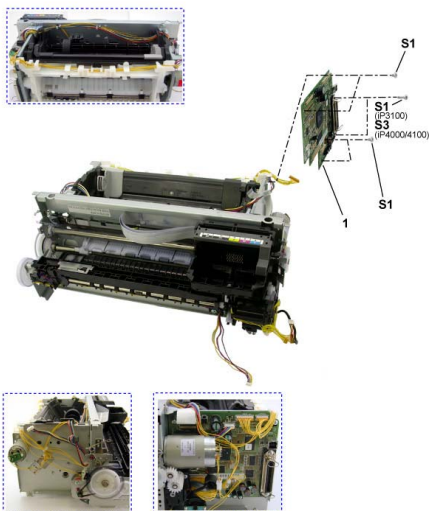

FIGURE 6 SHEET FEED UNIT

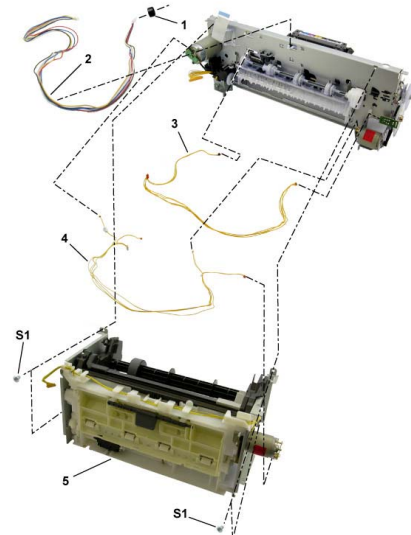

FIGURE 7 INK ABSORBER

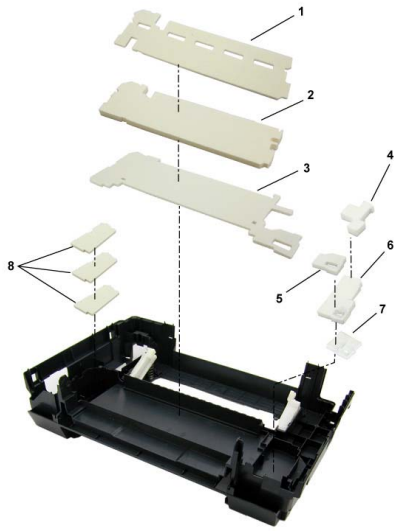

FIGURE 8 CARRIAGE UNIT

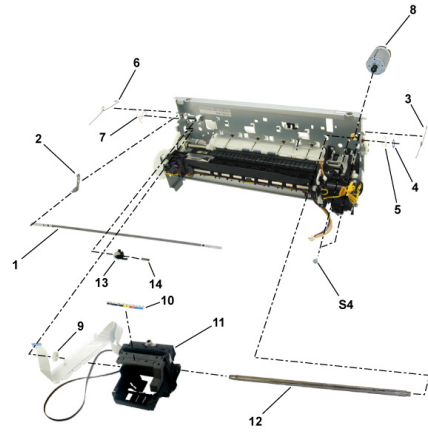

FIGURE 9 PURGE UNIT

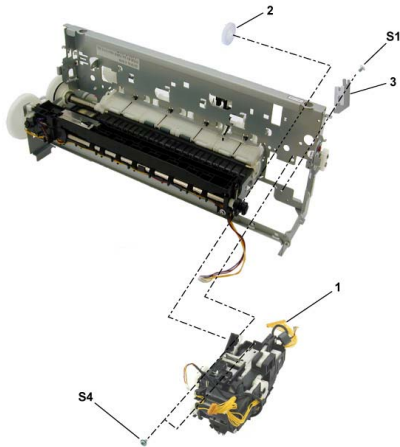

FIGURE 10 PLATEN UNIT

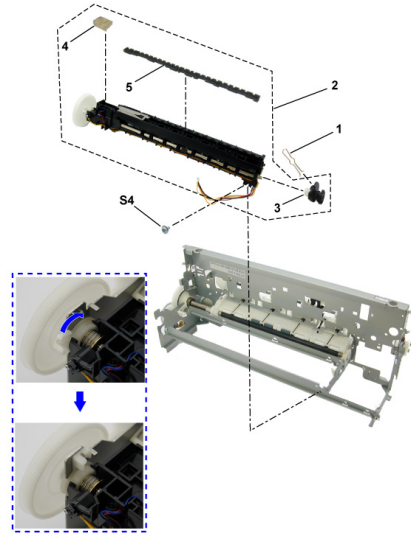

FIGURE 11 PAPER FEED & CARRIAGE LIFT PART (PIXUS iP3100)

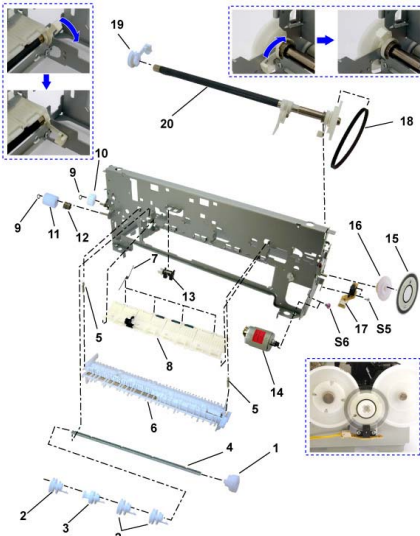

FIGURE 12 PAPER FEED & CARRIAGE LIFT PART (PIXMA iP4000/PIXUS iP4100)

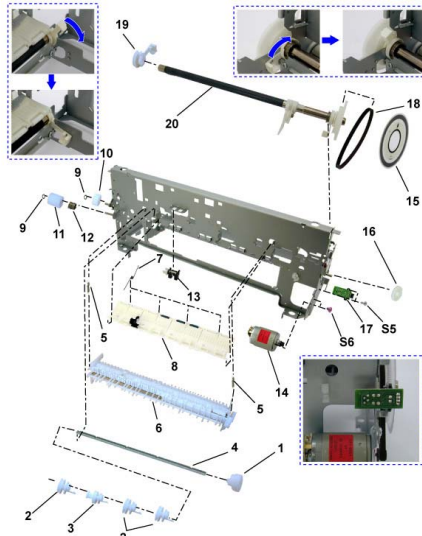

FIGURE 13 OPTION & CONSUMABLES

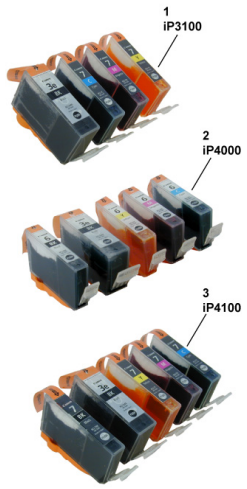

FIGURE 14 TOOL

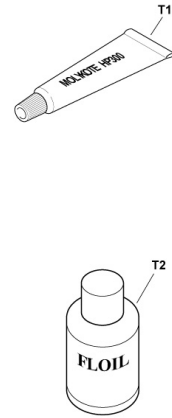

FIGURE 1 PRINTER & CASSETTE & PRINT HEAD

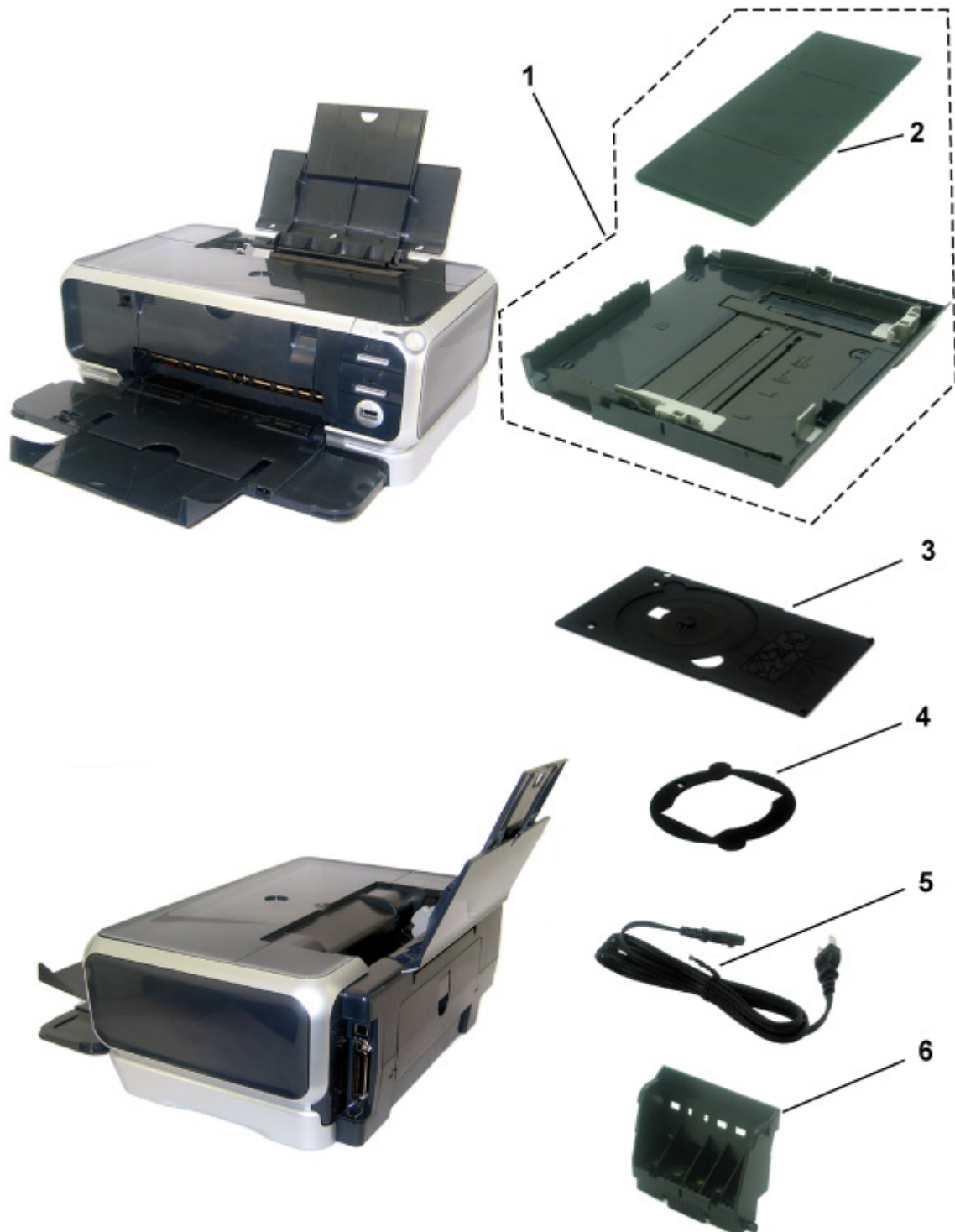

FIGURE & KEY No.		PART NUMBER	RANK	QTY	DESCRIPTION	REMARKS
1 -	1	QM2-1225-000		1	CASSETTE UNIT	FOR iP4000, 4100
		QM2-1390-000		1	CASSETTE UNIT	FOR iP3100
	2	QC1-4286-000		1	COVER, CASSETTE	
	3	QL2-0605-000		1	CDR TRAY ASS'Y	W/ CDR PRINTING
	4	QA4-1117-000		1	TRAY, CD SUB	W/ CDR PRINTING
	5	QH2-2724-000		1	CORD, POWER	100V-120V(JP)
		QH2-2725-000		1	CORD, POWER	100V-120V
		QH2-2726-000		1	CORD, POWER	220V-240V
		QH2-2727-000		1	CORD, POWER	220V-240V(AU)
		WT3-5156-000		1	CORD, POWER	220V-240V(GB, HK)
		WT3-5160-000		1	CORD, POWER	220V-240V(KR)
		WT3-5182-000		1	CORD, POWER	220V-240V(CHN)
	6	QY6-0042-000		1	PRINT HEAD	FOR iP3100
		QY6-0049-000		1	PRINT HEAD	FOR iP4000, 4100

FIGURE 2 AC ADAPTER

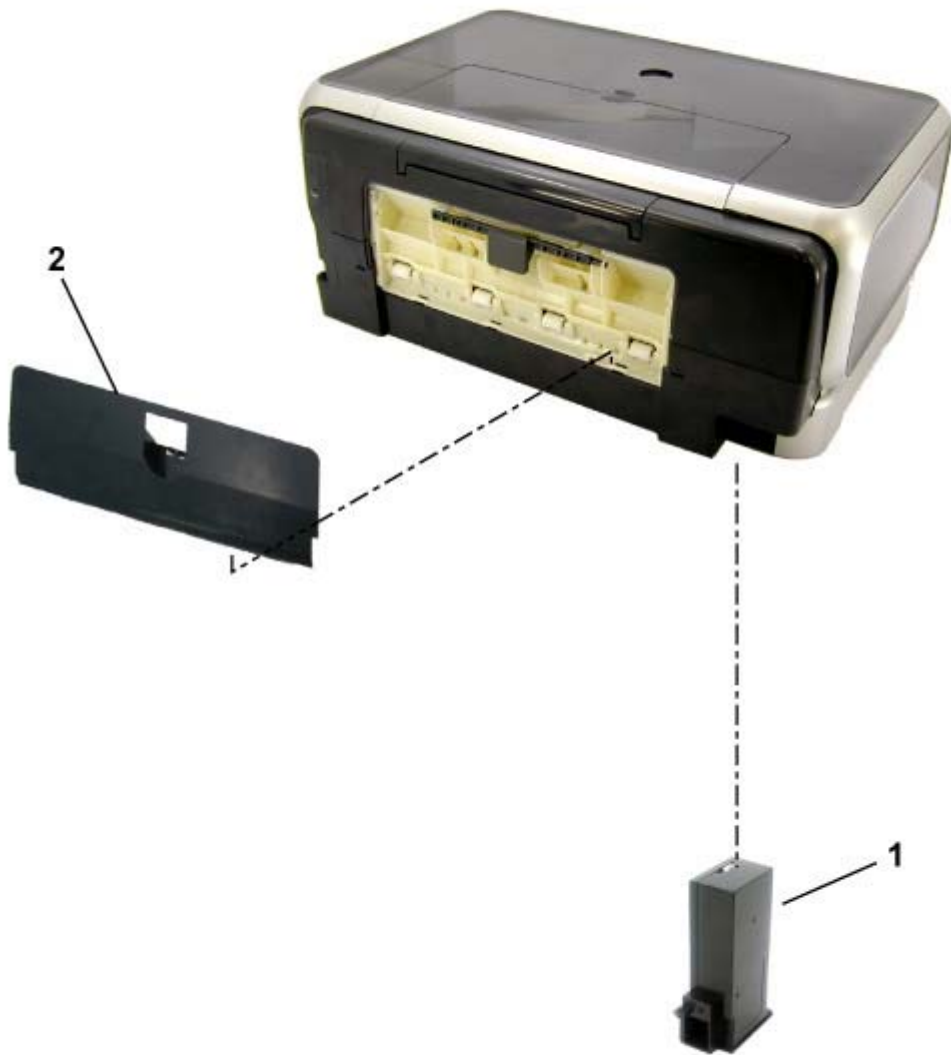

FIGURE & KEY No.		PART NUMBER	RANK	QTY	DESCRIPTION	REMARKS
2 -	1	QK1-0789-000		1	AC ADAPTER: 100V-120V 50/60HZ	FOR iP3100
		QK1-1093-000		1	AC ADAPTER: 100V-120V 50/60HZ	FOR iP4000,4100
		QK1-1095-000		1	AC ADAPTER: 220V-240V 50/60HZ	FOR iP4000
	2	QC1-4456-000		1	COVER, PAPER FEED GUIDE	FOR iP4000, 4100
		QC1-4895-000		1	COVER, PAPER FEED GUIDE	FOR iP3100

FIGURE 3 OPERATION PANEL UNIT & MAIN CASE UNIT

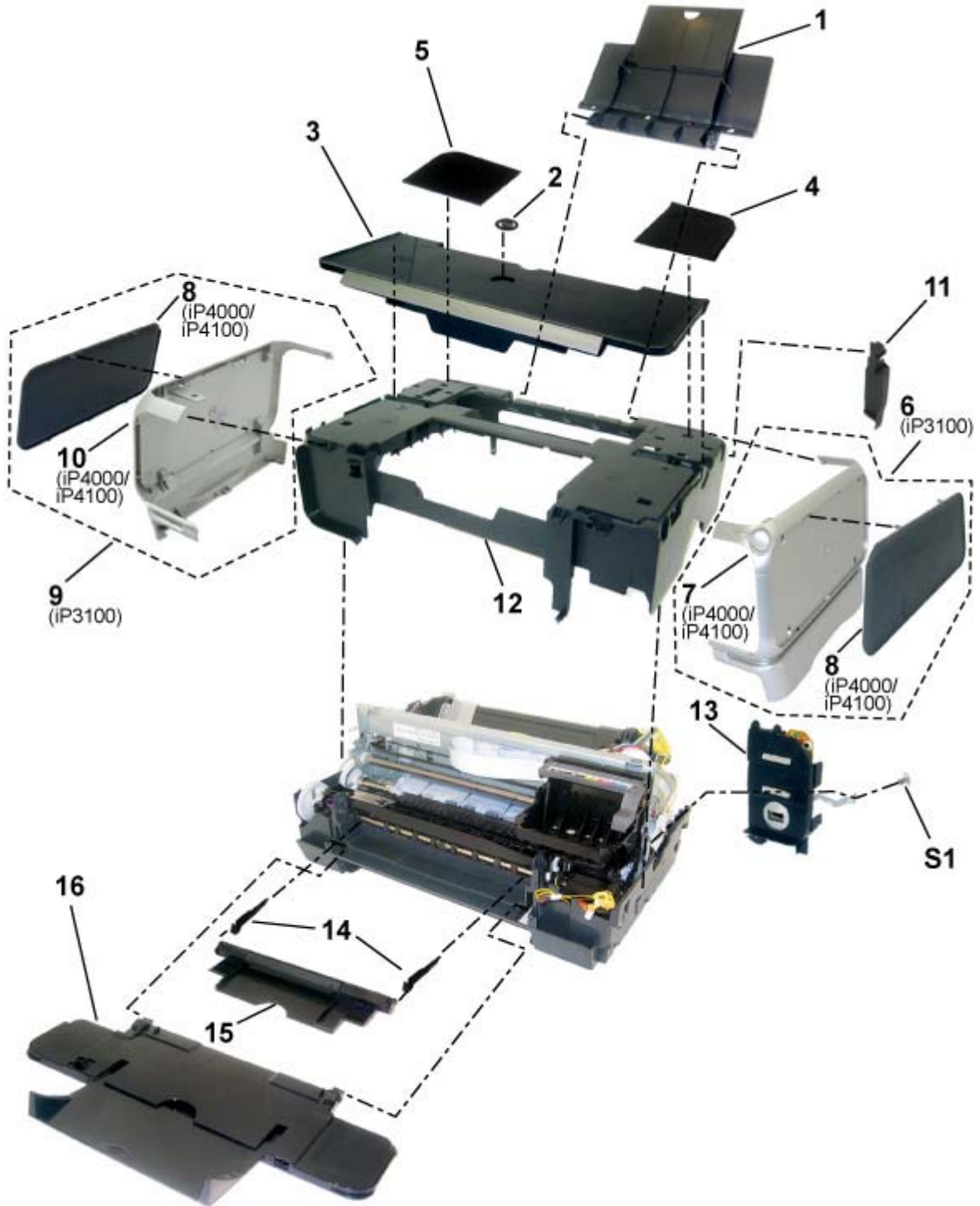

FIGURE & KEY No.		PART NUMBER	RANK	QTY	DESCRIPTION	REMARKS
3 -	1	QM2-1232-000		1	PAPER SUPPORT UNIT	FOR iP4000, 4100
		QM2-1256-000		1	PAPER SUPPORT UNIT	FOR iP3100
	2	QC1-4261-000		1	EMBLEM, PIXMA	
		QC1-4265-000		1	EMBLEM, PIXUS	
	3	QM2-1234-000		1	ACCESS COVER UNIT	FOR iP4000
		QM2-1236-000		1	ACCESS COVER UNIT	FOR iP4100
		QM2-1246-000		1	ACCESS COVER UNIT	FOR iP3100
	4	QC1-4216-000		1	COVER, MAIN CASE R	FOR iP4000, 4100
		QC1-4464-000		1	COVER, MAIN CASE R	FOR iP3100
	5	QC1-4217-000		1	COVER, MAIN CASE L	FOR iP4000, 4100
		QC1-4465-000		1	COVER, MAIN CASE L	FOR iP3100
	6	QM2-1382-000		1	SIDE COVER BASE R UNIT	FOR iP3100
	7	QM2-1231-000		1	SIDE COVER BASE R UNIT	FOR iP4000, 4100
	8	QC1-4231-000		2	COVER, SIDE	FOR iP4000, 4100
	9	QM2-1383-000		1	SIDE COVER BASE L UNIT	FOR iP3100
	10	QC1-4230-000		1	BASE, SIDE COVER L	FOR iP4000, 4100
	11	QC1-4255-000		1	COVER, I/F	FOR iP4000, 4100
		QC1-4468-000		1	COVER, I/F	FOR iP3100
	12	QM2-1204-000		1	MAIN CASE UNIT	FOR iP4000, 4100
		QM2-1244-000		1	MAIN CASE UNIT	FOR iP3100
	13	QM2-1230-000		1	OPERATION PANEL UNIT	FOR iP4000, 4100
		QM2-1389-000		1	OPERATION PANEL UNIT	FOR iP3100
	14	QC1-4252-000		2	ARM, RELEASE	
	15	QM2-1239-000		1	CDR TRAY BASE UNIT	W/ CDR PRINTING, FOR iP4000,4100
		QM2-1241-000		1	INNER COVER UNIT	W/O CDR PRINTING, FOR iP4000
		QM2-1388-000		1	CDR TRAY BASE UNIT	W/ CDR PRINTING, FOR iP3100
	16	QM2-1233-000		1	FRONT DOOR UNIT	FOR iP4000, 4100
		QM2-1387-000		1	FRONT DOOR UNIT	FOR iP3100

FIGURE 4 BOTTOM CASE UNIT

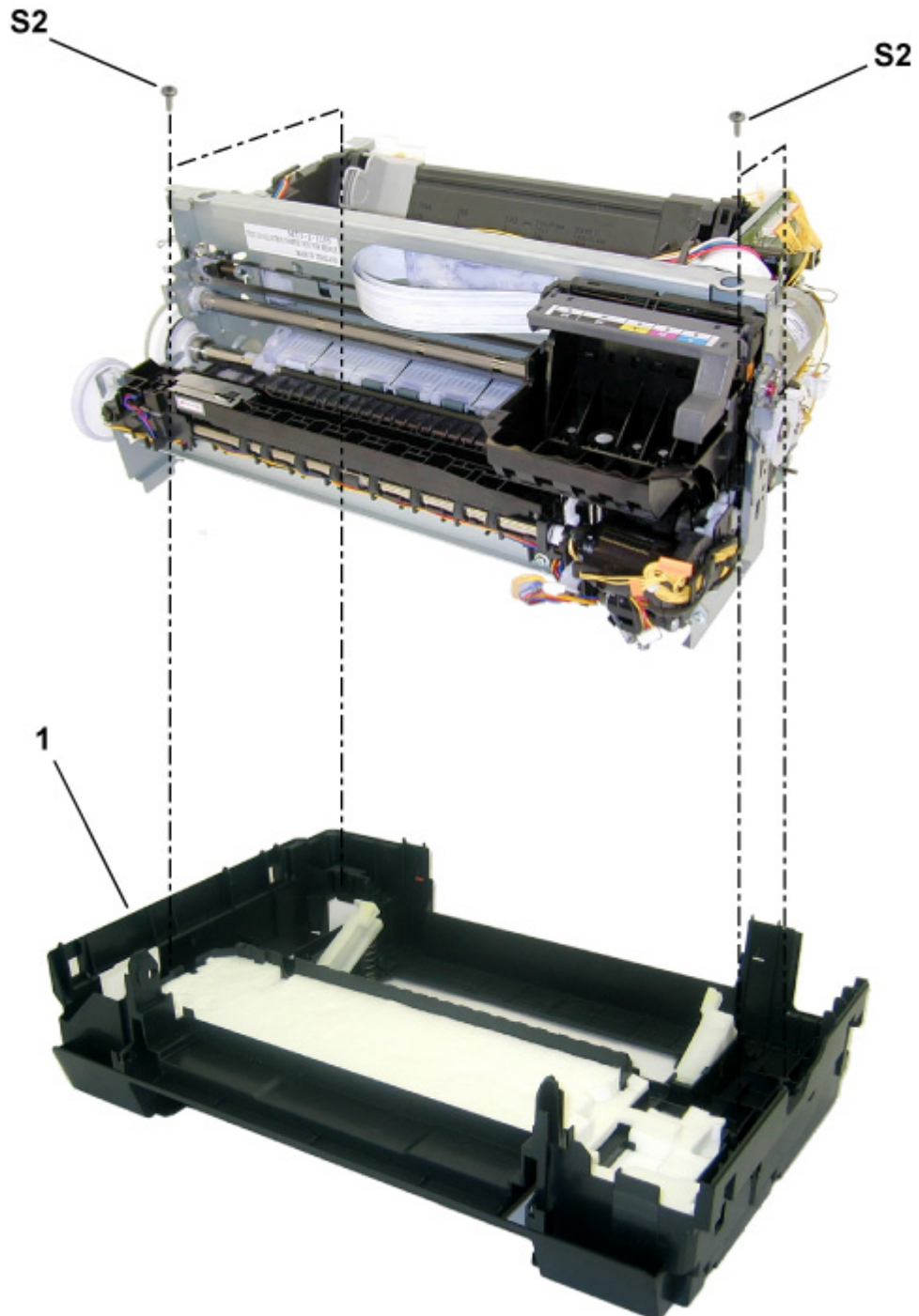

FIGURE & KEY No.		PART NUMBER	RANK	QTY	DESCRIPTION	REMARKS
4 -	1	QM2-1205-000		1	BOTTOM CASE UNIT	FOR iP4000, 4100
		QM2-1249-000		1	BOTTOM CASE UNIT	FOR iP3100

FIGURE 5 LOGIC BOARD

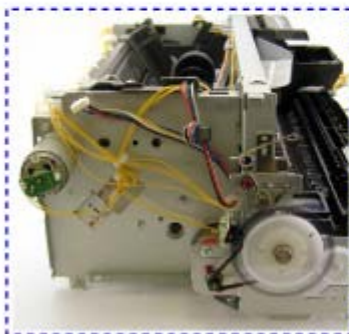
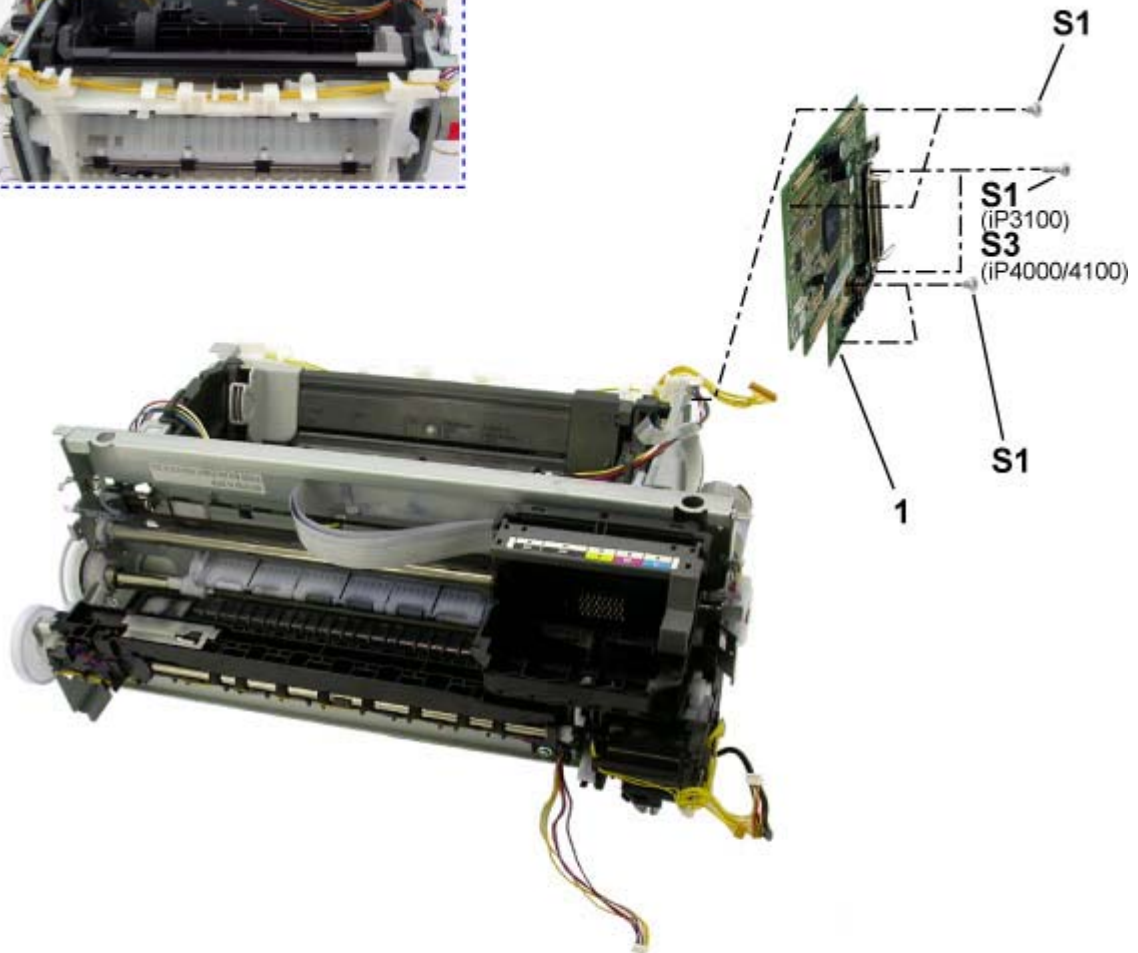

FIGURE & KEY No.		PART NUMBER	RANK	QTY	DESCRIPTION	REMARKS
5 -	1	QM2-1520-000		1	LOGIC BOARD ASS'Y	FOR iP3100
		QM2-1548-000		1	LOGIC BOARD ASS'Y	FOR iP4000, 4100

FIGURE 6 SHEET FEED UNIT

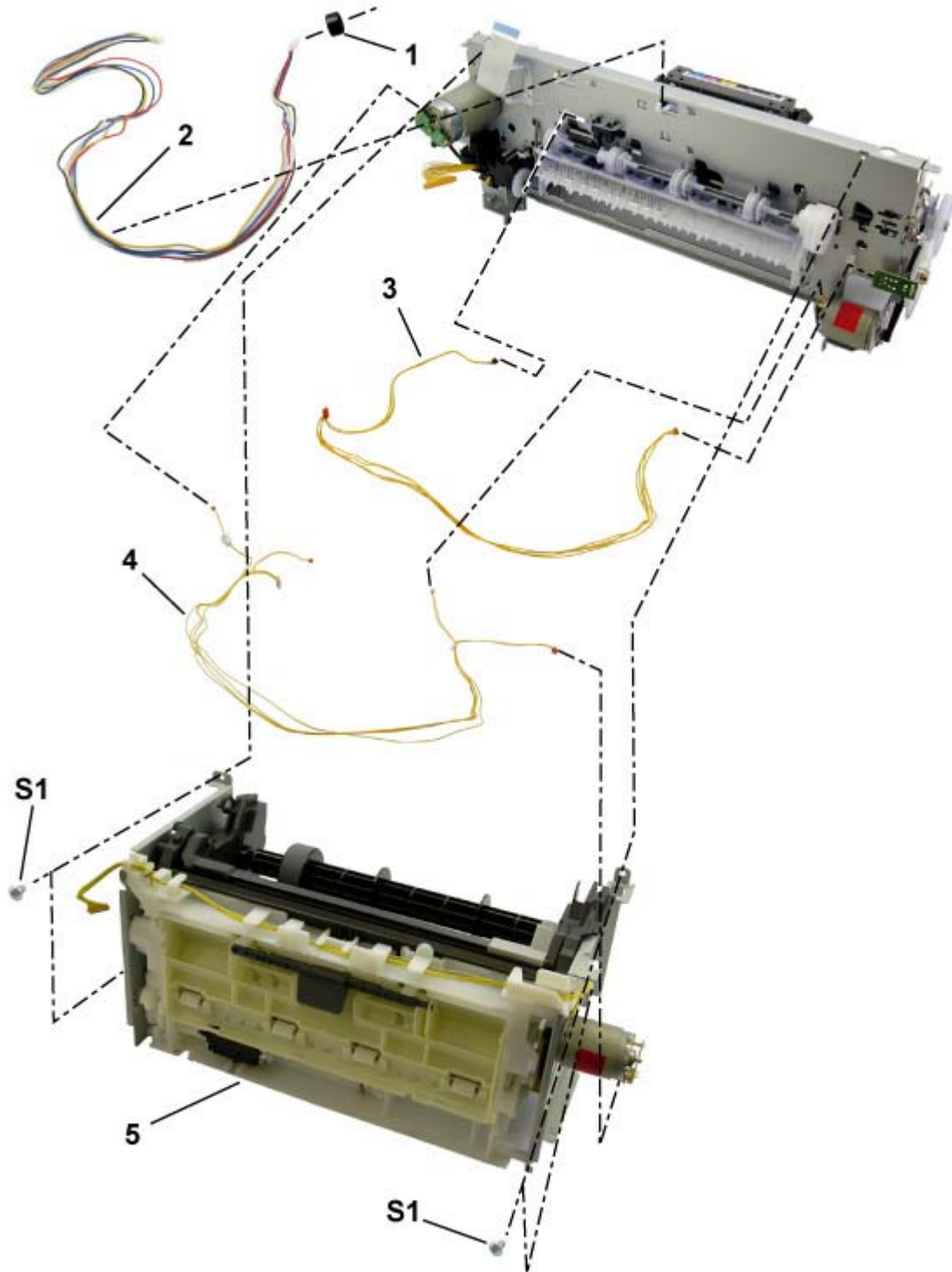

FIGURE & KEY No.		PART NUMBER	RANK	QTY	DESCRIPTION	REMARKS
6 -	1	WE8-6031-000		1	CORE, RING	
	2	QM2-1522-000		1	DC CONNECTOR ASS'Y	FOR iP3100
		QM2-1553-000		1	DC CONNECTOR ASS'Y	FOR iP4000, 4100
	3	QM2-1526-000		1	SENSOR MULTI HARNESS ASS'Y	FOR iP3100
		QM2-1557-000		1	SENSOR MULTI HARNESS ASS'Y	FOR iP4000, 4100
	4	QM2-1554-000		1	MOTOR MULTI HARNESS ASS'Y	
	5	QM2-1220-000		1	SHEET FEED UNIT	

FIGURE 7 INK ABSORBER

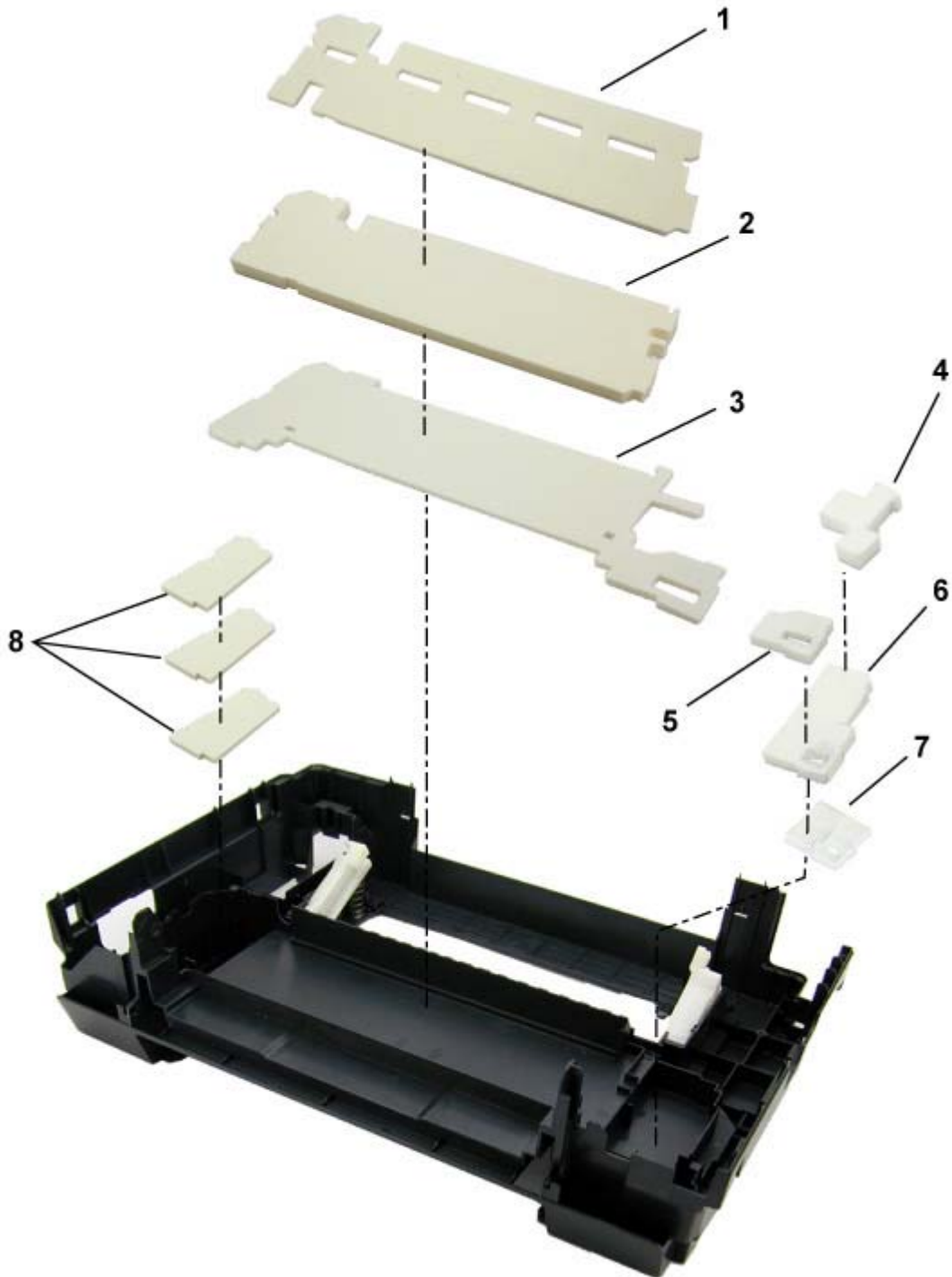

FIGURE & KEY No.		PART NUMBER	RANK	QTY	DESCRIPTION	REMARKS
7 -	1	QC1-4221-000		1	ABSORBER, INK	FOR iP4000, 4100
	2	QC1-4864-000		1	ABSORBER, INK	
	3	QC1-4222-000		1	ABSORBER, INK	
	4	QC1-4263-000		1	ABSORBER, INK	
	5	QC1-4223-000		1	ABSORBER, INK	
	6	QC1-4224-000		1	ABSORBER, INK	
	7	QC1-4264-000		1	ABSORBER, INK	
	8	QC1-4257-000		3	ABSORBER, INK	FOR iP4000, 4100

FIGURE 8 CARRIAGE UNIT

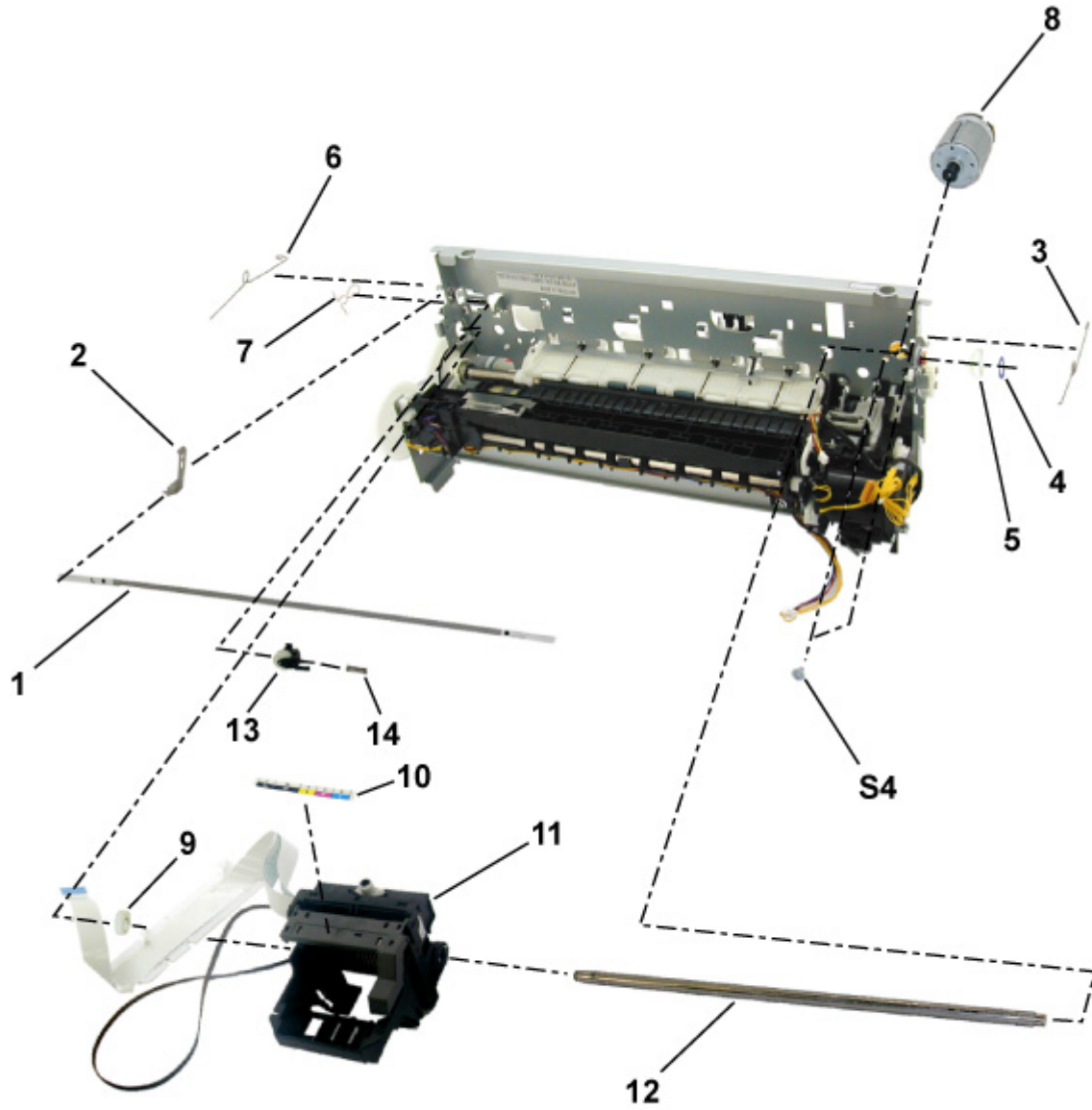

FIGURE & KEY No.		PART NUMBER	RANK	QTY	DESCRIPTION	REMARKS
8 -	1	QC1-4284-000		1	FILM, TIMING SLIT STRIP	
	2	QA4-0990-000		1	SPRING, LEAF	
	3	QC1-4280-000		1	CLIP, SHAFT R	
	4	QC1-2289-000		1	RING, CARRIAGE SHAFT	
	5	QC1-4282-000		1	CAM, CARRIAGE SHAFT R	
	6	QC1-4279-000		1	CLIP, SHAFT L	
	7	QC1-4880-000		1	CLIP, CARRIAGE SHAFT	
	8	QK1-0545-000		1	MOTOR, CARRIAGE	
	9	QC1-4281-000		1	CAM, CARRIAGE SHAFT L	
	10	QC1-4283-000		1	LABEL, TANK	FOR iP4000
		QC1-4876-000		1	LABEL, TANK	FOR iP4100
		QC1-4886-000		1	LABEL, TANK	FOR iP3100
	11	QM2-1209-000		1	CARRIAGE UNIT	FOR iP4000, 4100
		QM2-1250-000		1	CARRIAGE UNIT	FOR iP3100
	12	QC1-4274-000	N	1	SHAFT, CARRIAGE	
	13	QL2-0597-000		1	IDLER PULLEY ASS'Y	
	14	QC1-2290-000		1	SPRING, COIL	FOR iP4000, 4100
		QS4-2112-000		1	SPRING, COIL	FOR iP3100

FIGURE 9 PURGE UNIT

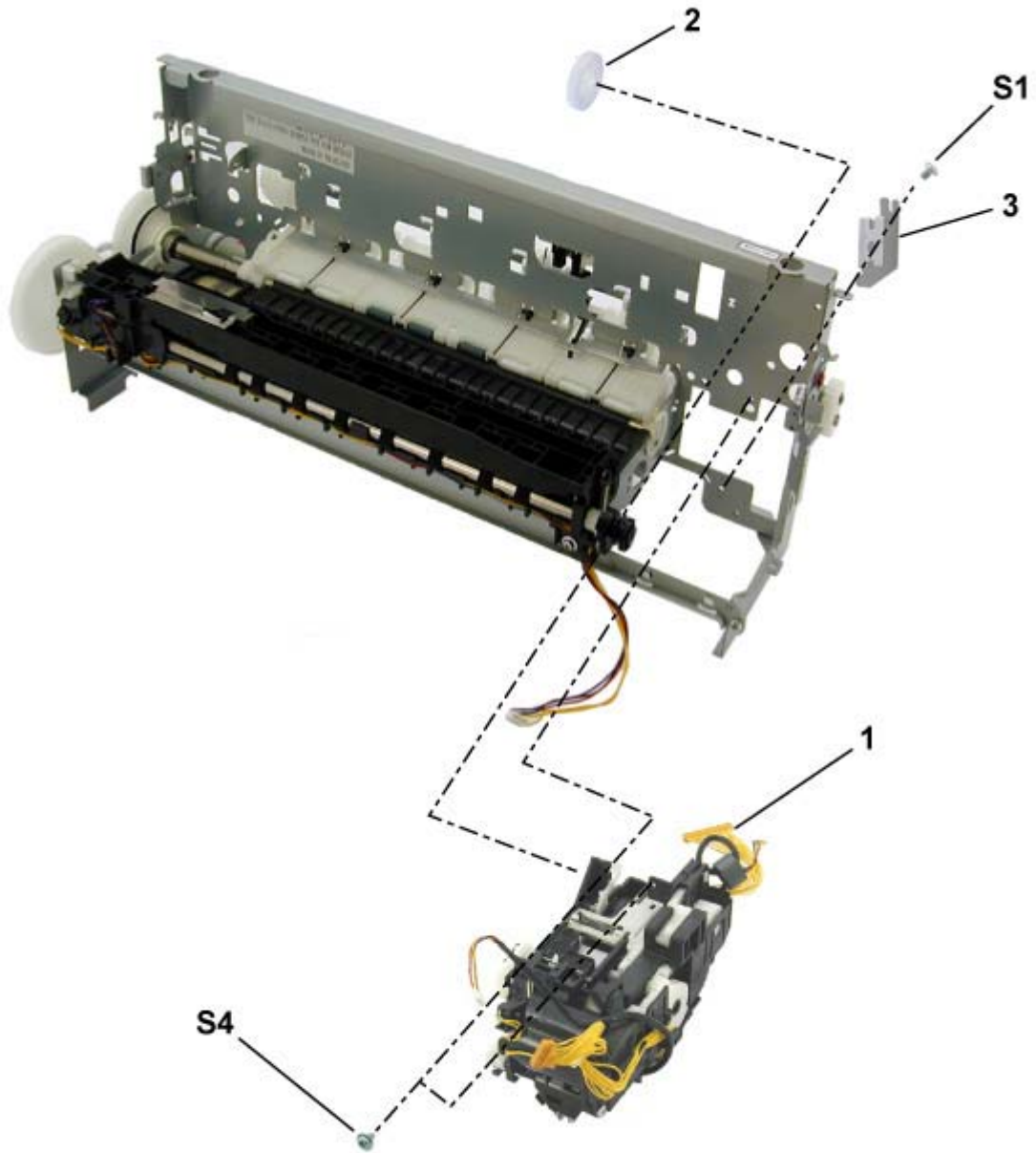

FIGURE & KEY NO.		PART NUMBER	RANK	QTY	DESCRIPTION	REMARKS
9 -	1	QM2-1210-000		1	PURGE UNIT	FOR iP4000, 4100
		QM2-1252-000		1	PURGE UNIT	FOR iP3100
	2	QC1-4390-000		1	GEAR, TRANSMISSION	
	3	QC1-4875-000	N	1	PLATE, PURGE	

FIGURE 10 PLATEN UNIT

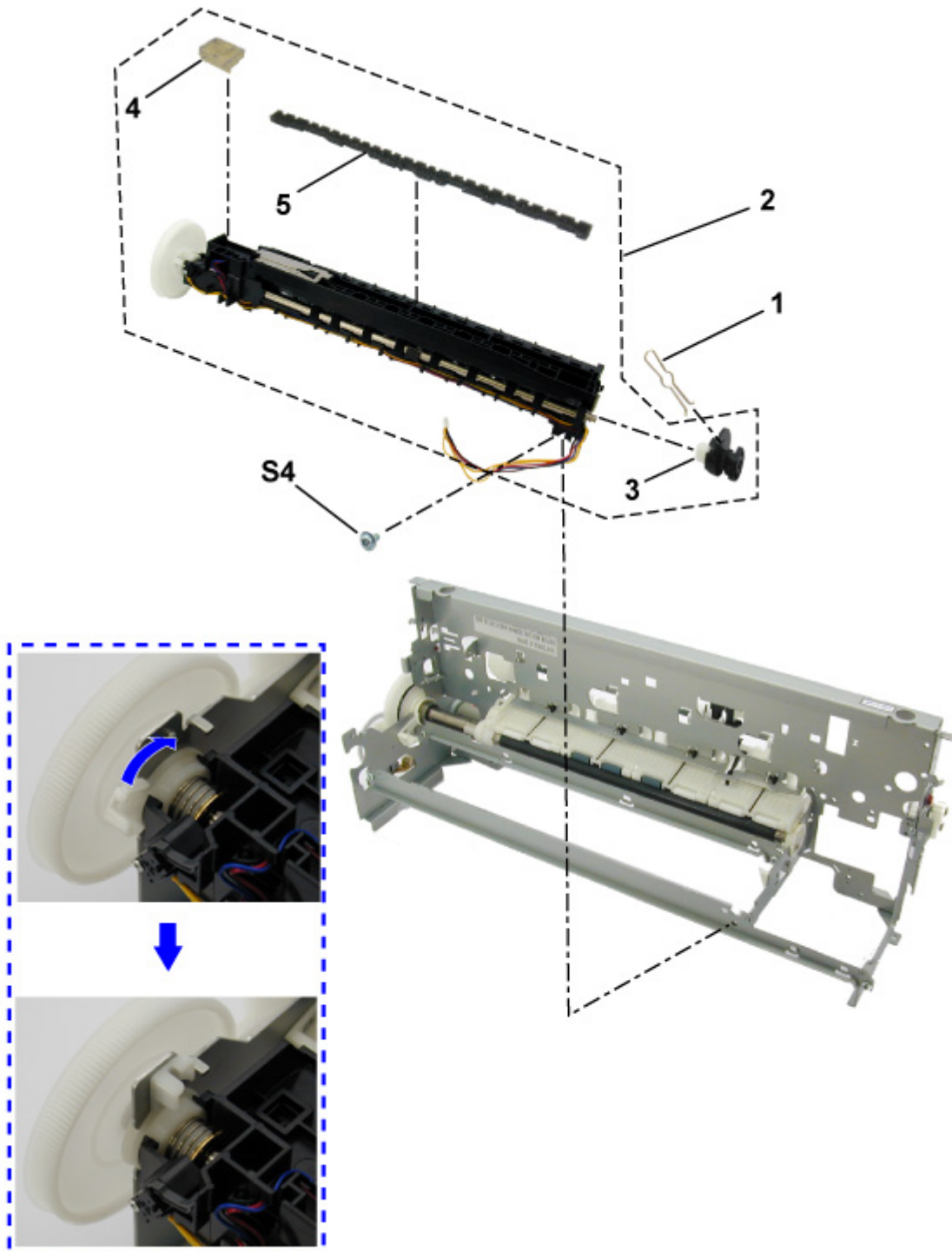

FIGURE & KEY No.		PART NUMBER	RANK	QTY	DESCRIPTION	REMARKS
10 -	1	QC1-5850-000		1	SPRING, VALVE CAM	
	2	QM2-1215-000		1	PLATEN UNIT	FOR iP4000, 4100
		QM2-1384-000		1	PLATEN UNIT	FOR iP3100
	3	QC1-4376-000		1	CAM, VALVE	
	4	QC1-4867-000		1	ABSORBER, INK	FOR iP4000, 4100
		QC1-4899-000		1	ABSORBER, INK	FOR iP3100
	5	QC1-4368-000		1	ABSORBER, INK	

FIGURE 11 PAPER FEED & CARRIAGE LIFT PART (PIXUS iP3100)

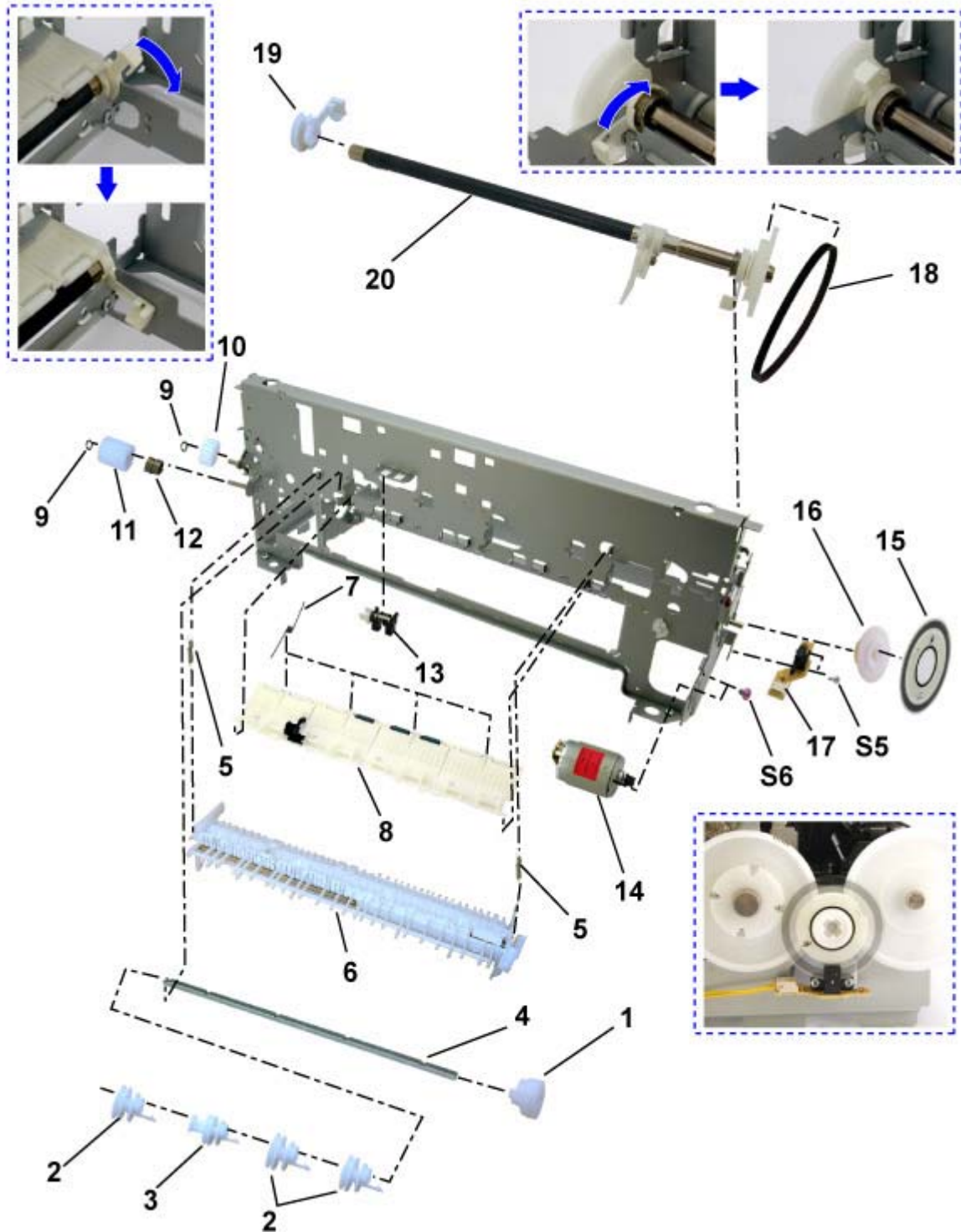

FIGURE & KEY No.		PART NUMBER	RANK	QTY	DESCRIPTION	REMARKS
11 -	1	QC1-4333-000		1	GEAR, LIFT SHAFT	
	2	QC1-4332-000		3	CAM, LIFT SHAFT	
	3	QC1-4837-000		1	CAM, PAPER END RELEASE	
	4	QC1-4331-000	N	1	SHAFT, LIFT	
	5	QU1-2098-000		2	SPRING, HOOK END COIL	
	6	QM2-1226-000		1	PAPER GUIDE UNIT	
	7	QC1-4346-000		4	SPRING, TORSION	
	8	QM2-1235-000		1	PRESSURE ROLLER ASS'Y	
	9	QC1-4391-000		2	RING, LIFT TRANSMISSION GEAR	
	10	QC1-4327-000		1	GEAR, LIFT TRANSMISSION	
	11	QC1-4328-000		1	GEAR, LIFT TRANSMISSION	
	12	QC1-4329-000		1	SPRING, COIL	
	13	WG8-5624-000		1	IC, PHOTO INTERRUPTER	
	14	QK1-0550-000		1	MOTOR, PAPER FEED	
	15	QC1-4851-000		1	FILM, TIMING SLIT DISK	FOR iP3100
	16	QC1-4486-000		1	GEAR, EJECT	FOR iP3100
	17	QM2-1545-000		1	TIMING SENSOR UNIT	FOR iP3100
	18	QC1-4836-000		1	BELT, PAPER FEED	
	19	QC1-4351-000		1	BUSHING	
	20	QL2-0613-000		1	FEED ROLLER ASS'Y	FOR iP3100

FIGURE 12 PAPER FEED & CARRIAGE LIFT PART (PIXMA iP4000/ PIXUS iP4100)

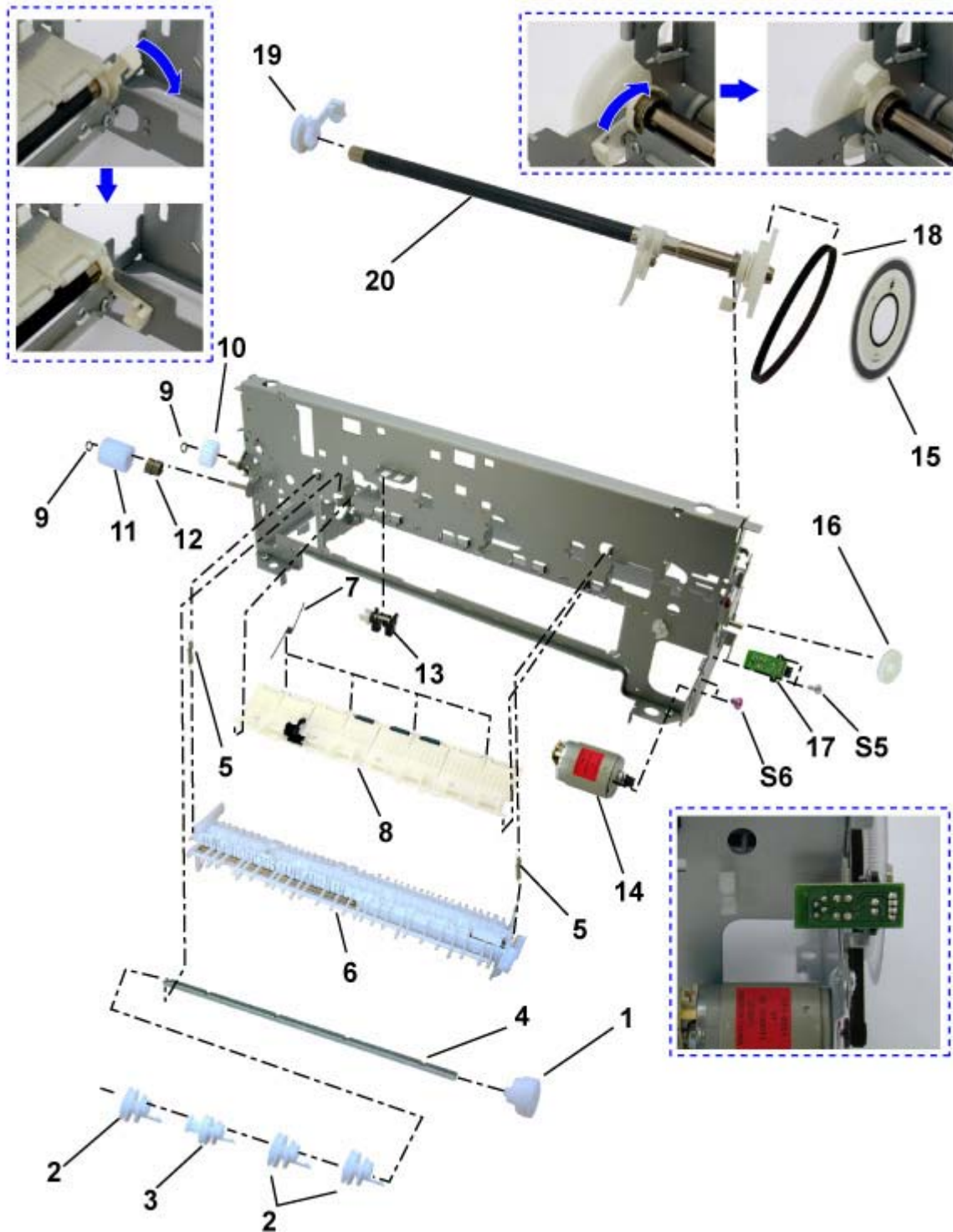

FIGURE & KEY No.		PART NUMBER	RANK	QTY	DESCRIPTION	REMARKS
12 -	1	QC1-4333-000		1	GEAR, LIFT SHAFT	
	2	QC1-4332-000		3	CAM, LIFT SHAFT	
	3	QC1-4837-000		1	CAM, PAPER END RELEASE	
	4	QC1-4331-000	N	1	SHAFT, LIFT	
	5	QU1-2098-000		2	SPRING, HOOK END COIL	
	6	QM2-1226-000		1	PAPER GUIDE UNIT	
	7	QC1-4346-000		4	SPRING, TORSION	
	8	QM2-1235-000		1	PRESSURE ROLLER ASS'Y	
	9	QC1-4391-000		2	RING, LIFT TRANSMISSION GEAR	
	10	QC1-4327-000		1	GEAR, LIFT TRANSMISSION	
	11	QC1-4328-000		1	GEAR, LIFT TRANSMISSION	
	12	QC1-4329-000		1	SPRING, COIL	
	13	WG8-5624-000		1	IC, PHOTO INTERRUPTER	
	14	QK1-0550-000		1	MOTOR, PAPER FEED	
	15	QC1-4833-000		1	FILM, TIMING SLIT DISK	FOR iP4000, 4100
	16	QC1-4340-000		1	GEAR, EJECT	FOR iP4000, 4100
	17	QM2-1213-000		1	TIMING SENSOR UNIT	FOR iP4000, 4100
	18	QC1-4836-000		1	BELT, PAPER FEED	
	19	QC1-4351-000		1	BUSHING	
	20	QL2-0598-000		1	FEED ROLLER ASS'Y	FOR iP4000, 4100

FIGURE 13 OPTION & CONSUMABLES

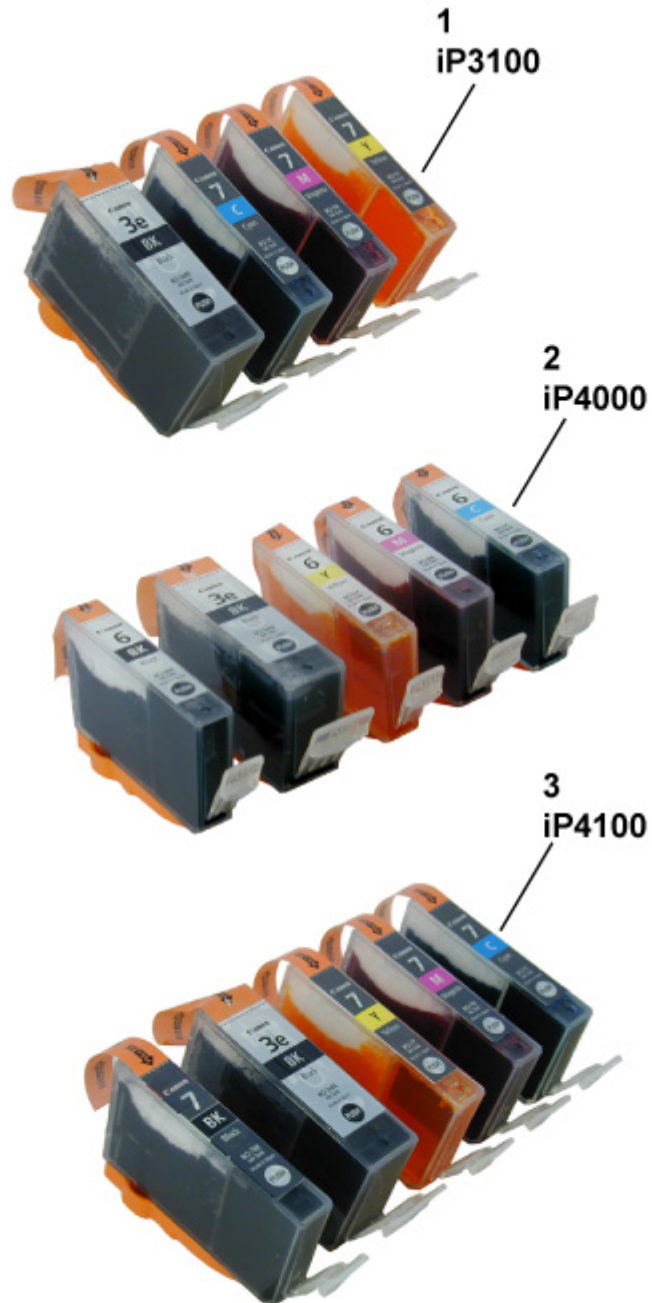

FIGURE & KEY No.		PART NUMBER	RANK	QTY	DESCRIPTION	REMARKS
13 -	1	NPN		1	BLACK INK TANK BCI-3eBK	CONSUMABLES
		NPN		1	BLACK INK TANK BCI-7C	CONSUMABLES
		NPN		1	BLACK INK TANK BCI-7M	CONSUMABLES
		NPN		1	BLACK INK TANK BCI-7Y	CONSUMABLES
	2	NPN		1	BLACK INK TANK BCI-3eBK	CONSUMABLES
		NPN		1	BLACK INK TANK BCI-6BK	CONSUMABLES
		NPN		1	CYAN INK TANK BCI-6C	CONSUMABLES
		NPN		1	MAGENTA INK TANK BCI-6M	CONSUMABLES
		NPN		1	YELLOW INK TANK BCI-6Y	CONSUMABLES
	3	NPN		1	BLACK INK TANK BCI-3eBK	CONSUMABLES
		NPN		1	BLACK INK TANK BCI-7BK	CONSUMABLES
		NPN		1	BLACK INK TANK BCI-7C	CONSUMABLES
		NPN		1	BLACK INK TANK BCI-7M	CONSUMABLES
		NPN		1	BLACK INK TANK BCI-7Y	CONSUMABLES

D. SCREW & WASHER LIST

[Contents](#)

FIGURE & KEY No.		PART NUMBER	RANK	QTY	DESCRIPTION	REMARKS
S -	1	XB1-2300-405			SCREW, MACH.BH, M3X4	
	2	XA9-1335-000			SCREW, TP, M3X12	
	3	XB1-2301-205			SCREW, MACHINE, M3X12	
	4	XB6-7300-605			SCREW, MACHINE, WASHER HEAD, M3x6	
	5	XB1-2200-505			SCREW, MACH, TRUSS HEAD, M2X5	
	6	XA9-1437-000			SCREW, BIND, M2.6X4(REDF)	

FIGURE 14 TOOL

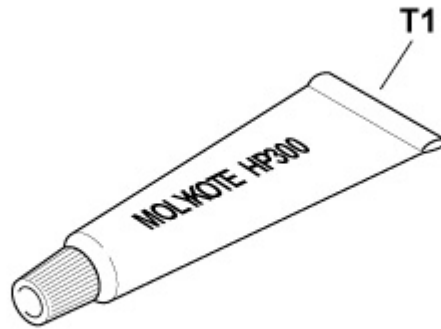

FIGURE & KEY No.		PART NUMBER	RANK	QTY	DESCRIPTION	REMARKS
T -	1	QY9-0035-000		1	GREASE, MOLYKOTE HP300	
	2	QY9-0057-000		1	LUBE, FLOIL KG107A, OIL	

F. NUMERICAL INDEX

PART NUMBER	FIGURE & KEY No.		DESCRIPTION
QA4-0990-000	8 -	2	SPRING, LEAF
QA4-1117-000	1 -	4	TRAY, CD SUB
QC1-2289-000	8 -	4	RING, CARRIAGE SHAFT
QC1-2290-000	8 -	14	SPRING, COIL
QC1-4216-000	3 -	4	COVER, MAIN CASE R
QC1-4217-000	3 -	5	COVER, MAIN CASE L
QC1-4221-000	7 -	1	ABSORBER, INK
QC1-4222-000	7 -	3	ABSORBER, INK
QC1-4223-000	7 -	5	ABSORBER, INK
QC1-4224-000	7 -	6	ABSORBER, INK
QC1-4230-000	3 -	10	BASE, SIDE COVER L
QC1-4231-000	3 -	8	COVER, SIDE
QC1-4252-000	3 -	14	ARM, RELEASE
QC1-4255-000	3 -	11	COVER, I/F
QC1-4257-000	7 -	8	ABSORBER, INK
QC1-4261-000	3 -	2	EMBLEM, PIXMA
QC1-4263-000	7 -	4	ABSORBER, INK
QC1-4264-000	7 -	7	ABSORBER, INK
QC1-4265-000	3 -	2	EMBLEM, PIXUS
QC1-4274-000	8 -	12	SHAFT, CARRIAGE
QC1-4279-000	8 -	6	CLIP, SHAFT L
QC1-4280-000	8 -	3	CLIP, SHAFT R
QC1-4281-000	8 -	9	CAM, CARRIAGE SHAFT L
QC1-4282-000	8 -	5	CAM, CARRIAGE SHAFT R
QC1-4283-000	8 -	10	LABEL, TANK
QC1-4284-000	8 -	1	FILM, TIMING SLIT STRIP
QC1-4286-000	1 -	2	COVER, CASSETTE
QC1-4327-000	11 -	10	GEAR, LIFT TRANSMISSION
	12 -	10	
QC1-4328-000	11 -	11	GEAR, LIFT TRANSMISSION
	12 -	11	
QC1-4329-000	11 -	12	SPRING, COIL
	12 -	12	
QC1-4331-000	11 -	4	SHAFT, LIFT
	12 -	4	
QC1-4332-000	11 -	2	CAM, LIFT SHAFT
	12 -	2	
QC1-4333-000	11 -	1	GEAR, LIFT SHAFT
	12 -	1	
QC1-4340-000	12 -	16	GEAR, EJECT
QC1-4346-000	11 -	7	SPRING, TORSION
	12 -	7	

PART NUMBER	FIGURE & KEY No.		DESCRIPTION
QC1-4351-000	11 -	19	BUSHING
	12 -	19	
QC1-4368-000	10 -	5	ABSORBER, INK
QC1-4376-000	10 -	3	CAM, VALVE
QC1-4390-000	9 -	2	GEAR, TRANSMISSION
QC1-4391-000	11 -	9	RING, LIFT TRANSMISSION GEAR
	12 -	9	
QC1-4456-000	2 -	2	COVER, PAPER FEED GUIDE
QC1-4464-000	3 -	4	COVER, MAIN CASE R
QC1-4465-000	3 -	5	COVER, MAIN CASE L
QC1-4468-000	3 -	11	COVER, I/F
QC1-4486-000	11 -	16	GEAR, EJECT
QC1-4833-000	12 -	15	FILM, TIMING SLIT DISK
QC1-4836-000	11 -	18	BELT, PAPER FEED
	12 -	18	
QC1-4837-000	11 -	3	CAM, PAPER END RELEASE
	12 -	3	
QC1-4851-000	11 -	15	FILM, TIMING SLIT DISK
QC1-4864-000	7 -	2	ABSORBER, INK
QC1-4867-000	10 -	4	ABSORBER, INK
QC1-4875-000	9 -	3	PLATE, PURGE
QC1-4876-000	8 -	10	LABEL, TANK
QC1-4880-000	8 -	7	CLIP, CARRIAGE SHAFT
QC1-4886-000	8 -	10	LABEL, TANK
QC1-4895-000	2 -	2	COVER, PAPER FEED GUIDE
QC1-4899-000	10 -	4	ABSORBER, INK
QC1-5850-000	10 -	1	SPRING, VALVE CAM
QH2-2724-000	1 -	5	CORD, POWER
QH2-2725-000	1 -	5	CORD, POWER
QH2-2726-000	1 -	5	CORD, POWER
QH2-2727-000	1 -	5	CORD, POWER
QK1-0545-000	8 -	8	MOTOR, CARRIAGE
QK1-0550-000	11 -	14	MOTOR, PAPER FEED
	12 -	14	
QK1-0789-000	2 -	1	AC ADAPTER: 100V-120V 50/60HZ
QK1-1093-000	2 -	1	AC ADAPTER: 100V-120V 50/60HZ
QK1-1095-000	2 -	1	AC ADAPTER: 220V-240V 50/60HZ
QL2-0597-000	8 -	13	IDLER PULLEY ASS'Y
QL2-0598-000	12 -	20	FEED ROLLER ASS'Y
QL2-0605-000	1 -	3	CDR TRAY ASS'Y
QL2-0613-000	11 -	20	FEED ROLLER ASS'Y
QM2-1204-000	3 -	12	MAIN CASE UNIT
QM2-1205-000	4 -	1	BOTTOM CASE UNIT
QM2-1209-000	8 -	11	CARRIAGE UNIT

PART NUMBER	FIGURE & KEY No.		DESCRIPTION
QM2-1210-000	9 -	1	PURGE UNIT
QM2-1213-000	12 -	17	TIMING SENSOR UNIT
QM2-1215-000	10 -	2	PLATEN UNIT
QM2-1220-000	6 -	5	SHEET FEED UNIT
QM2-1225-000	1 -	1	CASSETTE UNIT
QM2-1226-000	11 -	6	PAPER GUIDE UNIT
	12 -	6	
QM2-1230-000	3 -	13	OPERATION PANEL UNIT
QM2-1231-000	3 -	7	SIDE COVER BASE R UNIT
QM2-1232-000	3 -	1	PAPER SUPPORT UNIT
QM2-1233-000	3 -	16	FRONT DOOR UNIT
QM2-1234-000	3 -	3	ACCESS COVER UNIT
QM2-1235-000	11 -	8	PRESSURE ROLLER ASS'Y
	12 -	8	
QM2-1236-000	3 -	3	ACCESS COVER UNIT
QM2-1239-000	3 -	15	CDR TRAY BASE UNIT
QM2-1241-000	3 -	15	INNER COVER UNIT
QM2-1244-000	3 -	12	MAIN CASE UNIT
QM2-1246-000	3 -	3	ACCESS COVER UNIT
QM2-1249-000	4 -	1	BOTTOM CASE UNIT
QM2-1250-000	8 -	11	CARRIAGE UNIT
QM2-1252-000	9 -	1	PURGE UNIT
QM2-1256-000	3 -	1	PAPER SUPPORT UNIT
QM2-1382-000	3 -	6	SIDE COVER BASE R UNIT
QM2-1383-000	3 -	9	SIDE COVER BASE L UNIT
QM2-1384-000	10 -	2	PLATEN UNIT
QM2-1387-000	3 -	16	FRONT DOOR UNIT
QM2-1388-000	3 -	15	CDR TRAY BASE UNIT
QM2-1389-000	3 -	13	OPERATION PANEL UNIT
QM2-1390-000	1 -	1	CASSETTE UNIT
QM2-1520-000	5 -	1	LOGIC BOARD ASS'Y
QM2-1522-000	6 -	2	DC CONNECTOR ASS'Y
QM2-1526-000	6 -	3	SENSOR MULTI HARNESS ASS'Y
QM2-1545-000	11 -	17	TIMING SENSOR UNIT
QM2-1548-000	5 -	1	LOGIC BOARD ASS'Y
QM2-1553-000	6 -	2	DC CONNECTOR ASS'Y
QM2-1554-000	6 -	4	MOTOR MULTI HARNESS ASS'Y
QM2-1557-000	6 -	3	SENSOR MULTI HARNESS ASS'Y
QS4-2112-000	8 -	14	SPRING, COIL
QU1-2098-000	11 -	5	SPRING, HOOK END COIL
	12 -	5	
QY6-0042-000	1 -	6	PRINT HEAD
QY6-0049-000	1 -	6	PRINT HEAD
QY9-0035-000	T -	1	GREASE, MOLYKOTE HP-300

PART NUMBER	FIGURE & KEY No.		DESCRIPTION
QY9-0057-000	T -	2	LUBE, FLOIL KG107A, OIL
WE8-6031-000	6 -	1	CORE, RING
WG8-5624-000	11 -	13	IC, PHOTO INTERRUPTER
	12 -	13	
WT3-5156-000	1 -	5	CORD, POWER
WT3-5160-000	1 -	5	CORD, POWER
QY6-0049-000	1 -	6	PRINT HEAD
QY9-0035-000	T -	1	GREASE, MOLYKOTE HP-300
QY9-0057-000	T -	2	LUBE, FLOIL KG107A, OIL
WE8-6031-000	6 -	1	CORE, RING
WG8-5624-000	11 -	13	IC, PHOTO INTERRUPTER
	12 -	13	
WT3-5156-000	1 -	5	CORD, POWER
WT3-5160-000	1 -	5	CORD, POWER
WT3-5182-000	1 -	5	CORD, POWER
XA9-1335-000	S -	2	SCREW, TP, M3X12
XA9-1437-000	S -	6	SCREW, BIND, M2.6X4(REDF)
XB1-2200-505	S -	5	SCREW, MACH, TRUSS HEAD, M2X5
XB1-2300-405	S -	1	SCREW, MACH.BH, M3X4
XB1-2301-205	S -	3	SCREW, MACHINE, M3X12
XB6-7300-605	S -	4	SCREW, MACHINE, WASHER HEAD, M3x6