

BJC-3000

SERVICE MANUAL

REVISION 0

Canon

AUG. 1999

QY8-1365-000

0899 SC 0.30-0

BJC-3000

SERVICE MANUAL

Canon

Application

This manual has been issued by Canon Inc. for qualified persons to learn technical theory, installation, maintenance, and repair of products. This manual covers all localities where the products are sold. For this reason, there may be information in this manual that does not apply to your locality.

Corrections

This manual could include technical inaccuracies or typographical errors due to improvements or changes in the products. When changes occur in applicable products or in the content of this manual, Canon will release technical information as the need arises. In the event of major changes in the contents of this manual over a long or short period, Canon will issue a new editions of this manual.

The following paragraph does not apply to any countries where such provisions are inconsistent with local law.

Trademarks

The product names and company names described in this manual are the registered trademarks of the individual companies.

Copyright

This manual is copyrighted with all rights reserved. Under the copyright laws, this manual may not be copied, reproduced or translated into another language, in whole or in part, without the written consent of Canon Inc., except in the case of internal business use.

Copyright © 1999 by Canon Inc.

CANON INC.

BJ Products Quality Support Dept.

16-1, Shimonoge 3-chome, Takatsu-ku, Kawasaki-shi, Kanagawa 213, Japan

This manual has been produced on an Apple Power Macintosh G3 personal computer and Apple LaserWriter 600/16 laser beam printer; artworks of printing films were printed on Valityper® 4300J. All page layouts, logos, and parts-list data were saved with Canon Optical Disc Subsystem mo-5001S™ and Optical Disc Cartridge mo-502M™, and Interface Kit mo-IF2™ for Macintosh. All graphics were produced with MACROMEDIA FREEHAND™ 7.0J. All documents and all page layouts were created with QuarkXpress™ 3.3 Japanese version.

I. ABOUT THIS MANUAL

This manual is divided into five sections, and contains information required for serving the unit.

Part 1: Product Specifications

This section contains outlines and product specifications of the unit.

Product
Specifications

Part 2: Maintenance

This section explains how to maintain the unit. Descriptions and adjustment of assembly/disassembly and verification methods after assembly/disassembly are included.

Maintenance

Part 3: Operation

This section explains how to operate the unit properly. Operation procedures for service modes are explained.

Operation

Part 4: Troubleshooting

This section explains how to find out possible causes of troubles and units/parts to be replaced. It is divided into two parts: troubleshooting by error indications and by symptoms.

Troubleshooting

Part 5: Appendix

This section includes block diagrams of the unit and information to technically understand the hardware (applied for new techniques only). This section also includes pin arrangements.

Appendix



Sufficient information regarding assembly/disassembly is not given in this manual. Refer to the illustrations in the separate *Parts Catalog*.

II. TABLE OF CONTENTS

	<i>Part 1: Product Specifications</i>
Page	
1 - 1	1. PRODUCT OUTLINE
1 - 1	1.1 Product Outline
1 - 2	1.2 Features
1 - 3	2. SPECIFICATIONS
1 - 3	2.1 Printer Specifications
1 - 3	2.1.1 Printer specifications
1 - 3	2.1.2 Printer service life
1 - 4	2.2 Paper Specifications
1 - 4	2.2.1 Paper size/basis weight
1 - 4	2.2.2 Paper type/setting
1 - 5	2.2.3 Printable area
1 - 5	2.3 BJ Cartridge Specifications
1 - 6	2.4 Scanner Cartridge Specifications
1 - 6	2.4.1 Scannable area
1 - 7	2.5 Interface Specifications
1 - 7	2.5.1 Parallel interface
1 - 7	2.5.2 Serial interface
1 - 8	2.6 Printer/Scanner Driver Types
1 - 9	3. PRINTER PACKING
1 - 10	4. INSTALLATION
1 - 10	4.1 Installation Location
1 - 10	4.2 Setup Procedures
1 - 10	4.2.1 Connecting the interface cable
1 - 10	4.2.2 Connecting the power
1 - 11	5. NAME OF THE PARTS AND THEIR FUNCTIONS
1 - 12	6. PRODUCT CODE LIST
	 <i>Part 2: Maintenance</i>
2 - 1	1. REGULAR REPLACEMENT AND MAINTENANCE
2 - 1	1.1 Parts for Regular Replacement
2 - 1	1.2 Periodic Maintenance
2 - 2	2. DISASSEMBLY/REASSEMBLY
2 - 2	2.1 List of Tools
2 - 3	2.2 Disassembly/Reassembly Precautions
2 - 3	2.2.1 Ink stain precautions (ink path/ink mist)
2 - 4	2.2.2 Static electricity damage prevention
2 - 5	2.2.3 Transportation precautions
2 - 5	2.2.4 Spur deformation precautions
2 - 6	2.2.5 Feed gear section precautions
2 - 7	2.3 Disassembling and Reassembling the Printer
2 - 7	2.3.1 Carriage lock release
2 - 7	2.3.2 Removing tap screws
2 - 8	2.3.3 Reattaching and removing the upper cover unit
2 - 8	2.3.4 Removing the printer unit
2 - 9	2.3.5 Removing the pressure roller unit
2 - 9	2.3.6 Position of spurs in the spur base unit
2 - 10	2.3.7 Removing the ASF unit
2 - 10	2.3.8 Removing the head gap adjustment unit
2 - 11	2.4 Grease Application
2 - 12	2.5 Adjustments and Settings after Disassembly/Reassembly
2 - 12	2.5.1 List of adjustment items
2 - 13	2.5.2 When adjustment of the print head position is required

Page	
2 - 14	2.5.3 When EEPROM setting is required
2 - 14	2.5.4 When the carriage belt tension needs adjustment
2 - 15	2.5.5 When the ASF gear initial position adjustment is required
2 - 16	2.5.6 When the head gap needs adjustment
2 - 18	3. VERIFYING OPERATIONS AFTER DISASSEMBLY/REASSEMBLY
2 - 18	3.1 Methods
2 - 19	4. TRANSPORTING THE PRINTER
2 - 19	4.1 Preparation for Transportation

Part 3: Operation

3 - 1	1. FUNCTIONS RELATED TO PRINTER OPERATION
3 - 1	1.1 Status Indications
3 - 2	1.1.1 Status indications by the LED
3 - 3	1.1.2 Details of error conditions
3 - 4	1.1.3 BJ status monitor
3 - 5	1.2 Operations from the Computer
3 - 5	1.2.1 Function settings using the printer driver
3 - 6	1.3 Operations from the Printer
3 - 6	1.3.1 Cleaning
3 - 6	1.3.2 Nozzle check pattern print
3 - 6	1.3.3 Roller cleaning
3 - 8	2. SERVICE FUNCTIONS
3 - 8	2.1 Service Mode Operations
3 - 9	2.2 Service/Factory Test Print
3 - 10	2.3 EEPROM Information Print
3 - 11	2.4 Resetting the EEPROM
3 - 11	2.5 Model Settings with EEPROM
3 - 11	2.6 Ink Presence Check
3 - 11	2.7 Power Off/Carriage Lock

Part 4: Troubleshooting

4 - 1	1. TROUBLESHOOTING BY ERROR INDICATIONS
4 - 1	1.1 Initial Flow Chart
4 - 4	1.2 List of Errors (Indicator/error codes)
4 - 5	1.3 Troubleshooting by Error Indications
4 - 17	2. TROUBLESHOOTING BY SYMPTOMS
4 - 17	2.1 Troubleshooting by Symptoms

Page	<i>Part 5: Appendix</i>
5 - 1	1. TECHNICAL REFERENCE
5 - 1	1.1 About the Paper Feed Section
5 - 1	1.1.1 Paper feed functions
5 - 2	1.1.2 Structure of the paper feed components
5 - 3	1.1.3 Advanced paper feed function
5 - 3	1.1.4 Paper feed retry function
5 - 3	1.1.5 The print start position adjustment retry function
5 - 3	1.1.6 The form alignment function
5 - 4	1.2 About the Purge Unit
5 - 4	1.2.1 The capping and cleaning functions of the purge unit
5 - 5	1.2.2 Purge unit paper feed motor drive switching function
5 - 5	1.2.3 Purge unit structure and functions
5 - 7	1.3 About the Electrical Section
5 - 7	1.3.1 Electrical section block diagram
5 - 7	1.3.2 Power line block diagram
5 - 8	1.3.3 USB interface
5 - 9	1.3.4 Automatic interface switching function
5 - 9	1.3.5 Detection functions with sensors
5 - 10	1.4 About the BJ Cartridge
5 - 10	1.4.1 BJ cartridge structure
5 - 10	1.4.2 BJ cartridge print drive control
5 - 10	1.4.3 BJ cartridge identification
5 - 11	1.4.4 List of printing modes
5 - 12	1.5 About the Scanner Cartridge
5 - 12	1.5.1 Scanner block diagram and the data flow
5 - 13	1.5.2 Scan modes
5 - 14	1.5.3 Image gradation and bit data size
5 - 14	1.5.4 Scanner cartridge detection
5 - 14	1.5.5 Calibration operation based on the white calibration sheet
5 - 14	1.5.6 Scanning time and data size (reference)
5 - 15	2. CONNECTORS AND PIN LAYOUT
5 - 15	2.1 Control Board
5 - 19	2.2 Carriage Board
5 - 20	2.3 BJ Cartridge
5 - 21	2.4 Scanner Cartridge (Optional)
5 - 22	2.5 AC Adapter
5 - 22	2.6 DC Power Supply Cable
5 - 23	2.7 Carriage Motor
5 - 23	2.8 Paper Feed Motor
5 - 23	2.9 Ink Sensor

III. ILLUSTRATION INDEX

Page	<i>Part 1: Product Specifications</i>	
1 - 1	Figure 1- 1	Printer Appearance
1 - 5	Figure 1- 2	Printable Area
1 - 6	Figure 1- 3	Scannable Area
1 - 9	Figure 1- 4	Packing
1 -10	Figure 1- 5	Installation Space
1 -11	Figure 1- 6	Name of the Parts and Their Functions
	 <i>Part 2: Maintenance</i>	
2 - 3	Figure 2- 1	Ink Path
2 - 4	Figure 2- 2	Ink Mist
2 - 5	Figure 2- 3	Transportation Precautions
2 - 5	Figure 2- 4	Spurs
2 - 6	Figure 2- 5	Feed Gear Section Precautions
2 - 7	Figure 2- 6	Carriage Lock Release
2 - 8	Figure 2- 7	Reattaching and Removing the Upper Cover Unit
2 - 8	Figure 2- 8	Removing the Printer Unit
2 - 9	Figure 2- 9	Removing the Pressure Roller Unit
2 - 9	Figure 2-10	Position of Spurs in the Spur Base Unit (Bottom View)
2 -10	Figure 2-11	Removing the ASF Unit
2 -10	Figure 2-12	Head Gap Adjustment Board
2 -11	Figure 2-13	Grease Application Points
2 -13	Figure 2-14	Print Position Adjustment Patterns
2 -14	Figure 2-15	Carriage Belt Tension Adjustment
2 -15	Figure 2-16	ASF Drive Gear Initial Position
2 -15	Figure 2-17	ASF Gear Initial Position Adjustment
2 -16	Figure 2-18	Head Gap Adjustment 1
2 -17	Figure 2-19	Head Gap Adjustment 2
2 -19	Figure 2-20	Transporting the Printer
	 <i>Part 3: Operation</i>	
3 - 1	Figure 3- 1	Operation Panel
3 - 4	Figure 3- 2	Status Monitor (Sample)
3 - 5	Figure 3- 3	Printer Driver Utility (Sample)
3 - 7	Figure 3- 4	Nozzle Check Pattern Print (Color Sample)
3 - 9	Figure 3- 5	Service/Factory Test Printout (Sample)
3 -10	Figure 3- 6	EEPROM Information Print (Sample)
3 -11	Figure 3- 7	Ink Check

Page *Part 4: Troubleshooting*

Part 5: Appendix

5 - 1	Figure 5- 1	Paper Feed Path
5 - 2	Figure 5- 2	Paper Pick-Up Mechanism
5 - 3	Figure 5- 3	Form Alignment Function
5 - 5	Figure 5- 4	Purge Unit Structure
5 - 7	Figure 5- 5	Block Diagram
5 - 7	Figure 5- 6	Power Line Block Diagram
5 - 8	Figure 5- 7	USB Data Transfer
5 - 8	Figure 5- 8	NRZI
5 - 9	Figure 5- 9	Sensor Positions
5 -10	Figure 5-10	Nozzle Arrangement
5 -12	Figure 5-11	Scanner Block Diagram
5 -15	Figure 5-12	Control Board
5 -15	Figure 5-13	Printer Diagram
5 -19	Figure 5-14	Carriage Board
5 -20	Figure 5-15	BJ Cartridge
5 -21	Figure 5-16	Scanner Cartridge
5 -22	Figure 5-17	AC Adapter
5 -22	Figure 5-18	DC Power Supply Cable
5 -23	Figure 5-19	Carriage Motor
5 -23	Figure 5-20	Paper Feed Motor
5 -23	Figure 5-21	Ink Sensor

IV. TABLE INDEX

Page	<i>Part 1: Product Specifications</i>
1 -12	TABLE 1- 1 PRODUCT CODE LIST
	<i>Part 3: Operation</i>
3 - 2	TABLE 3- 1 STATUS INDICATIONS BY THE LED
	<i>Part 4: Troubleshooting</i>
4 - 4	TABLE 4- 1 ERROR DISPLAY
	<i>Part 5: Appendix</i>
5 - 4	TABLE 5- 1 INK CONSUMPTION AMOUNT DURING CLEANING (REFERENCE)
5 -11	TABLE 5- 2 LIST OF PRINTING MODES
5 -13	TABLE 5- 3 SCAN MODES
5 -14	TABLE 5- 4 SCANNING TIME AND DATA SIZE (REFERENCE)

This page intentionally left blank.



Part 1

PRODUCT SPECIFICATIONS

Page	
1 - 1	1. PRODUCT OUTLINE
1 - 1	1.1 Product Outline
1 - 2	1.2 Features
1 - 3	2. SPECIFICATIONS
1 - 3	2.1 Printer Specifications
1 - 4	2.2 Paper Specifications
1 - 5	2.3 BJ Cartridge Specifications
1 - 6	2.4 Scanner Cartridge Specifications
1 - 7	2.5 Interface Specifications
1 - 8	2.6 Printer/Scanner Driver Types
1 - 9	3. PRINTER PACKING
1 - 10	4. INSTALLATION
1 - 10	4.1 Installation Location
1 - 10	4.2 Setup Procedures
1 - 11	5. NAME OF THE PARTS AND THEIR FUNCTIONS
1 - 12	6. PRODUCT CODE LIST

1. PRODUCT OUTLINE

1.1 Product Outline

"High-performance, Low-end Home Printer"

This printer is a powerful printer with high-speed, high-resolution, Photo-Realistic printing, is USB compliant, and can use an optional scanner cartridge.

High cost-performance is also achieved by separating the BJ cartridges and ink tanks, realizing separate ink tanks for all colors.

Product Specifications

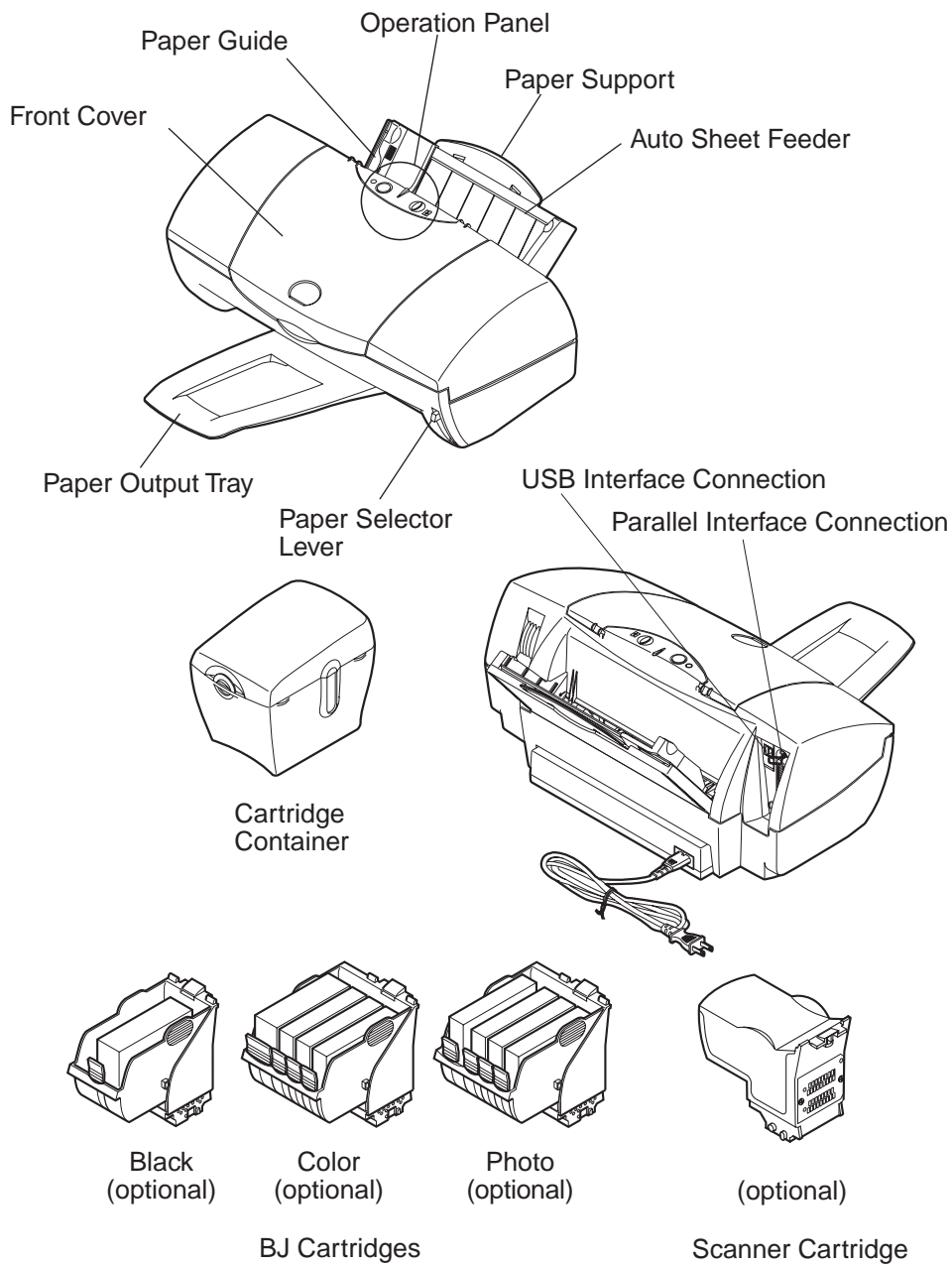

Figure 1-1 Printer Appearance

1.2 Features

- 1) Three types of BJ cartridges are available.
 - Pigment ink is adopted for the black cartridge and color cartridge, realizing modulated, high-density text printing.
 - High-quality printing, up to 1440 × 720 dpi, is achieved by drop modulation technology adopted for the Black, Color, and Photo BJ cartridges.
 - Separate BJ cartridges and ink tanks for all colors makes lower running costs possible.

Black BJ Cartridge (optional):	160 nozzles Separate ink tank (Pigment Black)
Color BJ Cartridge:	192 nozzles, Bk, C, M, Y (48 nozzles×4) in a vertical line Separate ink tanks for all colors (Pigment Black, Cyan, Magenta, and Yellow)
Photo-Color BJ Cartridge: (optional)	192 nozzles, PBk, PC, PM, Y (48 nozzles×4) in a vertical line Separate ink tanks for all colors (Dye Photo-Black, Photo-Cyan, Photo-Magenta, and Yellow)
- 2) Ink-out detection function with both optical and dot-count methods; transparent ink tanks enable visible confirmation.
- 3) USB and IEEE 1284 compatible 8-bit parallel interfaces.
- 4) Two buttons (*POWER*, *RESUME*), cover sensor, two-color LEDs (green/orange), with no beeper.
- 5) Optional scanner cartridge with maximum readout resolution of 720×720 dpi also available.

2. SPECIFICATIONS

2.1 Printer Specifications

2.1.1 Printer specifications

Type	Desktop serial printer			
Paper feeding method	Auto sheet feed only (no manual sheet feed available)			
Resolution	Maximum resolution 1440×720dpi			
Printing throughput (reference)		HS Mode	Standard Mode	HQ Mode
	BC-30 Black Cartridge			
	Black Text (PC Magazine)	8.1ppm	6.2ppm	2.5ppm
	New Monochrome Pattern (E)	9ppm*	6.8ppm*	2.5ppm
	BC-33 Color Cartridge			
	New Color Pattern (E)	4ppm*	2.8ppm	1.0ppm
	BC-34 Photo Cartridge			
	Full Address Printing	---	---	0.25ppm*
	*: Catalog specifications			
Printing direction	HS Mode (180dpi×180dpi)		bi-directional	
	HQ Mode (360dpi×360dpi, 720dpi×720dpi)		bi-directional	
	Fine Mode (360dpi×360dpi, 720dpi×720dpi, 1440dpi×720dpi)		unidirectional/bi-directional	
Max. print width	203 mm			
Line feed speed	5.6 "/S			
Interface	USB, IEEE 1284 compatible 8-bit parallel (compatible/nibble/ECP)			
ASF stacking capacity	Plain paper: Max 10mm (approx. 100 pages of 64 g/m ² paper) BJ printer paper: Max. 10mm (approx. 80 pages of high-resolution paper)			
Detection functions	Front cover open: Available Presence of BJ cartridge: Available BJ cartridge distinction: Available Ink out: Available Print position: None Paper out: Available Waste ink amount: Available Paper width: None			
Operation noise	Approx. 45dB(A) in conformance to the sound pressure level ISO 9296			
Environmental conditions	During operation	Temperature	5°C to 35°C (41°F to 95°F)	
		Humidity	10% to 90% RH (no condensation)	
	Non-operation	Temperature	0°C to 35°C (32°F to 95°F)	
		Humidity	5% to 95% RH (no condensation)	
Power supply	Input voltage/Frequency	Power consumption	Stand-by status	
	AC 100 to 120V 50/60Hz	Approx. 35W	Approx. 3W	
	AC 200 to 240V 50/60Hz	Approx. 35W	Approx. 3W	
External dimensions	Approx. 418mm W × 306mm D × 169mm H (with paper support retracted, and without the paper output tray)			
Weight	Approx. 3.7kg			
Standard conformance	Radio-wave interference: FCC, IC, CE Mark, Taiwan EMC, C-Tick, VCCI Electrical safety: UL, C-UL, CB Report, GS, CE Mark, FIMKO, Electric Commerce, AS, CCIB, SISIR, Korean Electric Commerce Environmental: Energy Star, Blue Angel			

2.1.2 Printer service life

The print quality can be assured during the product life given below, if the specified maintenance is conducted.

- 1) 20,000 printed sheets (1,500 character pattern printed in black) OR,
- 2) 6,000 printed sheets (7.5% duty color) OR,
- 3) 5 years of use, whichever comes first.

2.2 Paper Specifications

2.2.1 Paper size/basis weight

(1) Paper Size

A4, B5, A5, A5 Horizontal, Letter, Legal, Envelopes (Com #10/DL-size)

(2) Basis Weight

64 to 105g/m² with automatic feed

2.2.2 Paper type/setting

Media		Size	ASF Stacking Capacity	Selector Lever Position
Plain paper	---	A4/B5/ LTR/LGL/A5 (landscape/ portrait)	10mm or less (approx. 100 pages of 64g/m ² paper)	Up
Color bubble jet paper	LC-301*	A4/LTR	10mm or less	Up
High-resolution paper	HR-101*	A4/LTR	10mm or less	Up
Glossy photo paper	GP-301*	A4/LTR	10 pages	Up
Glossy film	HG-201*	A4/LTR	1 page	Up
OHP film	CF-102*	A4/LTR	30 pages or less	Up
Back print film	BF-102*	A4/LTR	10 pages or less	Up
Banner paper	BP-101*	A4/LTR	1 page	Down
T-shirt transfers	TR-201*	A4/LTR	1 page	Down
Glossy postcard	FM-101*	120mm×216mm	1 page	Up
Envelopes	COM #10	241mm×105mm	10 pages or less	Down
	DL-size	220mm×110mm	10 pages or less	Down

* : Special papers for BJ Printers



Incorrect paper selector lever positioning may result in paper mis-feeding or misprinting.

2.2.3 Printable area

A4, A5, B5, Letter (LTR), Legal (LGL) size

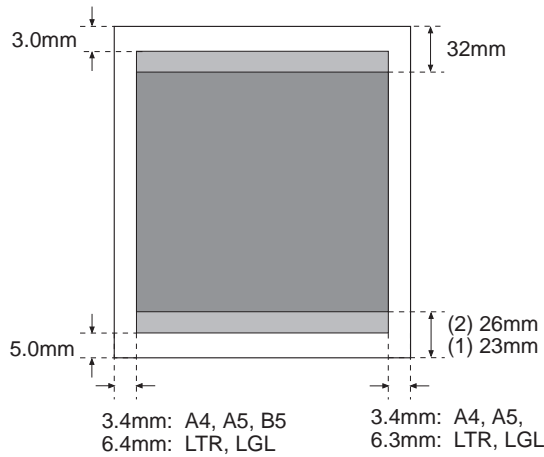

Envelopes

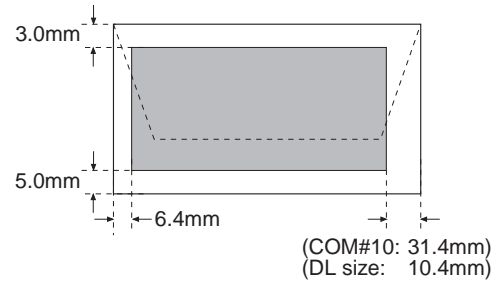

B5

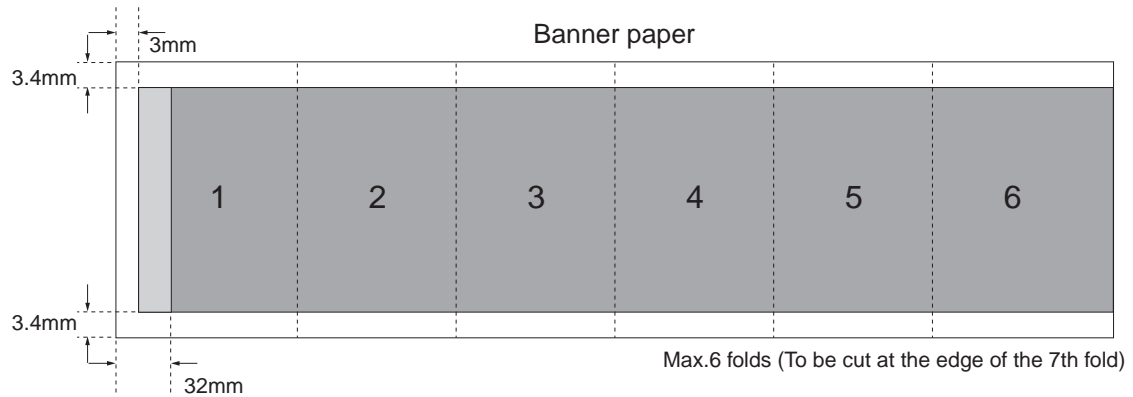

- : Recommended print area (1) Printing with BC-30
- : Printable area (2) Printing with BC-33 or BC-34

Figure 1-2 Printable Area

2.3 BJ Cartridge Specifications

	Black BJ Cartridge BC-30	Color BJ Cartridge BC-33	Photo BJ Cartridge BC-34Photo
Structure	Separate type ink tank	Separate type ink tank	Separate type ink tank
Head	160 nozzles (in a vertical line) Bk (160 nozzles×1)	192 nozzles (in a vertical line) Bk, C, M, Y (48 nozzles×4)	192 nozzles (in a vertical line) Bk, C, M, Y (48 nozzles×4)
Ink colors	Pigment Bk	Pigment Bk, C, M, Y	Dye PBk, PC, PM, Y
Ink tanks	BCI-3BK	BCI-3BK, BCI-3C, BCI-3M, BCI-3Y	BCI-3BK Photo BCI-3PC Photo BCI-3PM Photo, BCI-3Y
Weight	60g (without ink tank)	72g (without ink tanks)	75g (without ink tanks)
Service life	Approx. 5,000 pages	Approx. 3,000 pages	←
Printable pages (pages/cartridge)	Approx. 500 pages (standard 1,500 characters print in black)	Approx. 300 pages* (7.5% duty per color)	←

* as determined with the printable area of A4 paper.



2.4 Scanner Cartridge Specifications

Name	IS-32
Type	Cartridge replacement type color scanner
Resolution (dpi)	90×90, 180×180, 200×180, 300×360, 360×360, 720×720
Image sensor	Single-line, 256 pixel CCD
Light source	RGB (R; Red, G; Green, B; Blue)
Scanning method/direction	Sequential RGB light source switching method
Document feeding method	Place the document into the scanning holder and feed it through ASF
Interface	ECP/Nibble
External dimensions	Approx. 41 mm W × 90 mm D × 77 mm H
Weight	Approx. 100 g
Others	Raise the paper selector lever on the printer upward when scanning Scannable paper size: A4/LTR size or smaller (when used with the BJC-3000) Scannable paper thickness: 0.25 mm or less

2.4.1 Scannable area

For scanning, be sure to use the scanning holder to avoid paper jams. Place the image to scan in the scanning holder with the upper left corner fitted to the placement point.

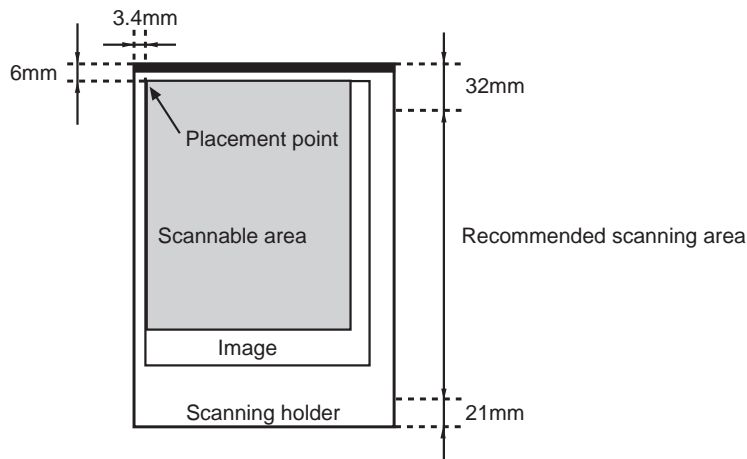

Figure 1-3 Scannable Area

Paper	Size (width × height: mm)	Scannable area (width × height: mm)
Postcard	100.0 × 148.0	93.2 × 138.0
A5	148.0 × 210.0	141.2 × 200.0
B5	182.0 × 257.0	175.2 × 247.0
A4**	210.0 × 297.0	203.2 × 287.0
Letter***	215.9 × 279.4 (8.5 × 11.0 inches)	208.2 × 269.4

* : Depending on the display resolution and scanning resolution, the area actually scanned can slightly differ.

** : The scanning holder packed with Scanner Cartridge IS-32 supports up to B5-sized paper.

To scan paper larger than B5, the option scanning holder (SH-101) should be used.

2.5 Interface Specifications

2.5.1 Parallel interface

1) Interface type

IEEE 1284 compatible parallel interface

2) Data transfer

8-bit parallel interface (supports nibble/ECP modes)

3) Signal voltage levels

Input:

"Low" level: 0.0V to +0.8V

"High" level: +2.4V to +5.0V

Output:

"Low" level: 0.0V to +0.8V

"High" level: +2.4V to +5.25V

4) Input/output

Each signal pulled up with +5V

5) Interface cable

Twisted-pair double shielded cable, shorter than 2.0m

IEEE 1284 compatible required

Material: AWG No. 28 or higher (AWG: American Wire Gauge)

6) Interface connector

Printer-side Amphenol 57-40360 (or equivalent)

Cable-side Amphenol 57-30360 (or equivalent)

7) Input/output signal and pin arrangements

Refer to *Part 5: 2. CONNECTORS AND PIN LAYOUT (Page 5-15)* for details.

2.5.2 Serial interface

1) Interface type

USB Interface (Universal Serial Bus; USB Specification Release Number 1.10)

2) Data transfer

Control transfer method

Bulk transfer method

3) Signal voltage level

Input:

Input difference sensitivity: +0.2V (Max)

Common-mode difference: +0.8V to +2.5V

Output:

Static output high: +2.8V to 3.6V

Static output low: less than +0.3V

4) Input/output

Each signal pulled up with 3.3V

5) Interface cable

Twisted-pair shielded cable

USB standard compatible required

Material AWG No.28, Data pair (AWG: American Wire Gauge)

AWG No.20 to No.28, Power distribution pair

6) Interface connector

Printer-side USB standard, Series B receptacle

Cable-side USB standard, Series B plug

7) Input/output signal and pin arrangements

Refer to *Part 5: 2. CONNECTORS AND PIN LAYOUT (Page 5-15)* for details.

2.6 Printer/Scanner Driver Types

The following table shows the relationship between available drivers and the interfaces for this printer.

	Printer Driver		Scanner Driver	
	Parallel I/F	USB I/F	Parallel I/F	USB I/F
Windows 95/98	fully supported	conditionally supported*	fully supported***	conditionally supported*
Windows NT 4.0	fully supported	not supported	fully supported***	not supported
Windows 2000	fully supported	not supported	not supported	not supported
Macintosh	---	fully supported**	---	fully supported**

* : Support for USB is provided, and the operation is guaranteed, with Windows 98-preinstalled computers.

** : Supported by iMac and Power Macintosh G3. Mac OS 8.1-installed iMac is necessary to be upgraded by iMac Update 1.0 for full support of USB.

*** : Common driver for Windows 95/98/NT 4.0

1) Windows Drivers

Win95/98 BJ Raster Printer Driver (IEEE 1284 compatible 8-bit parallel & USB supported)

WinNT4.0 BJ Raster Printer Driver

Win2000 BJ Raster Printer Driver

Win95/98/NT4.0 Scanner Driver IS Scan (Win2000 not supported)

2) Macintosh Drivers

Mac BJ Printer Driver (USB)

Mac Scanner Driver IS Scan (USB)

3. PRINTER PACKING

After unpacking the printer, make sure the items below are included:

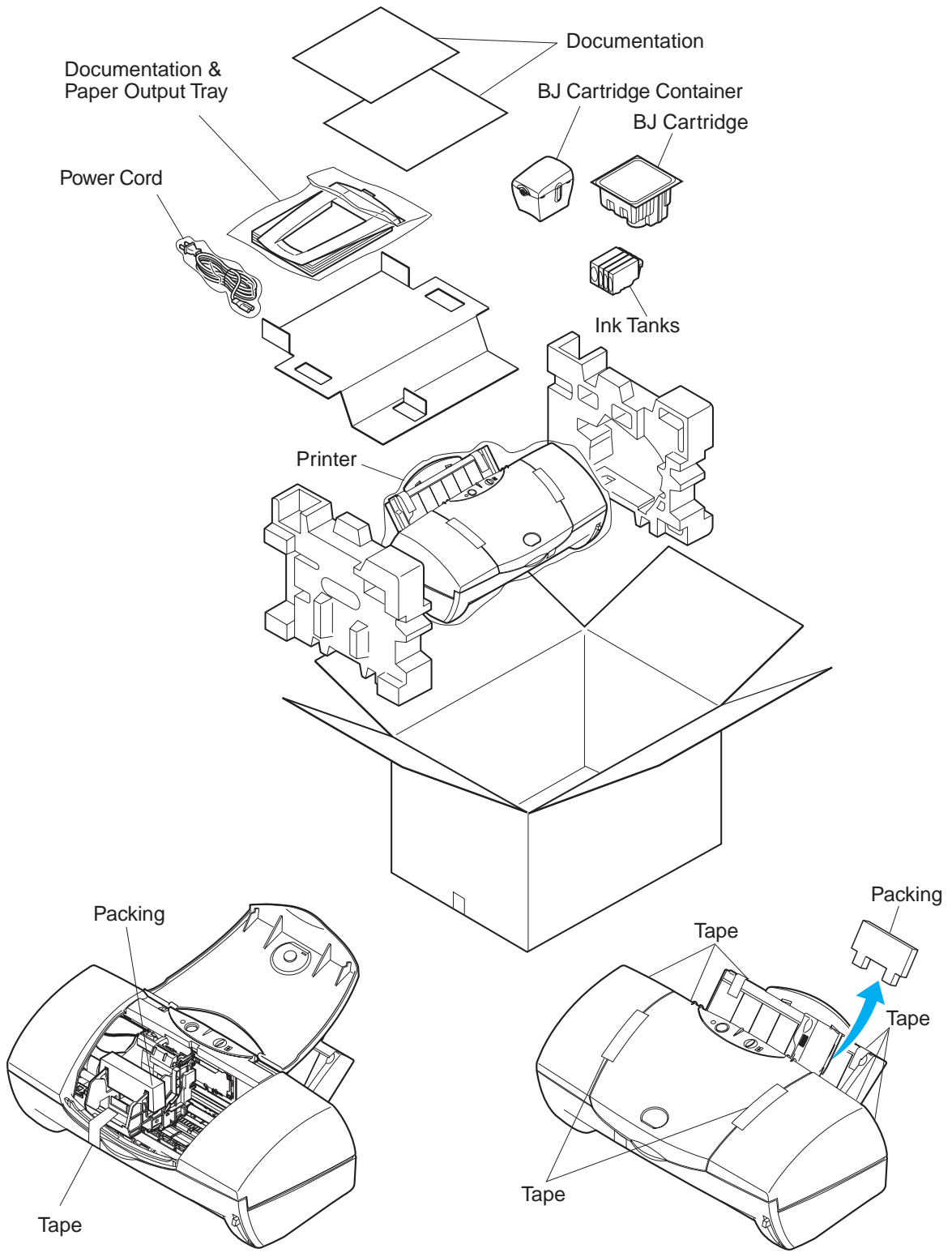

Product Specifications

Figure 1-4 Packing

4. INSTALLATION

Refer to the User's Manual for detailed installation procedures.

4.1 Installation Location

Allow enough space for the printer to be used with ease.

Refer to the diagram below for the printer's external dimensions for installation.

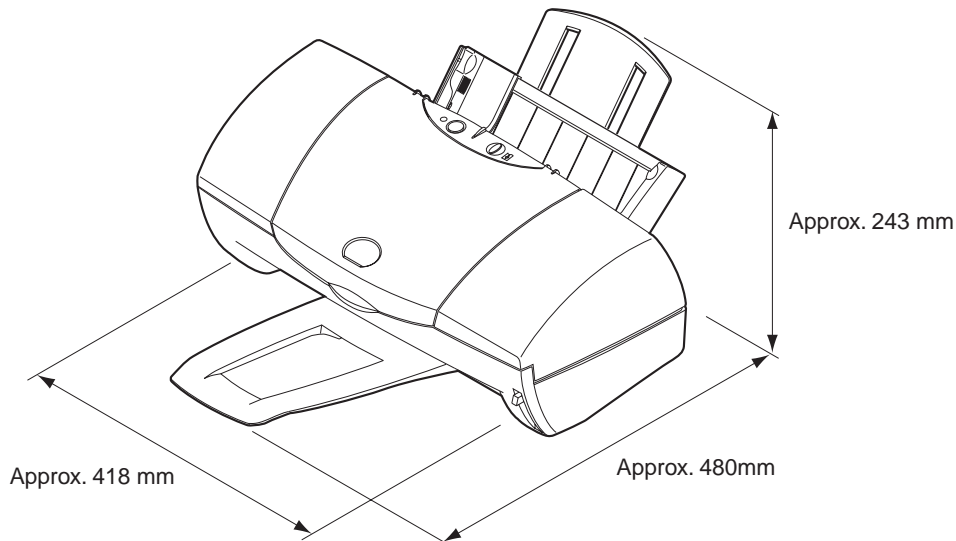

Figure 1-5 Installation Space

4.2 Setup Procedures

In order to prevent the potential difference between the computer and the printer, interface cables should be connected prior to connecting the AC power plug to the AC outlet.

4.2.1 Connecting the interface cable

- 1) Make sure that both the printer and the computer are turned off.
- 2) Connect the interface cable to the interface connector on the printer, and lock in place with the connector clips.
- 3) Connect the other end of the interface cable to a computer and secure in place.

4.2.2 Connecting the power

- 1) Connect the AC power plug to the AC outlet.
- 2) Press the *POWER* button on the printer to turn it on. Initialization will be carried out while the indicator blinks in green. After initialization is completed, the indicator lights in green. When a cartridge is not installed in the printer, the indicator blinks six times in orange and once in green, repeatedly. Also, the carriage will move to the cartridge replacement position.

5. NAME OF THE PARTS AND THEIR FUNCTIONS

The different parts of the printer and their functions are shown below.

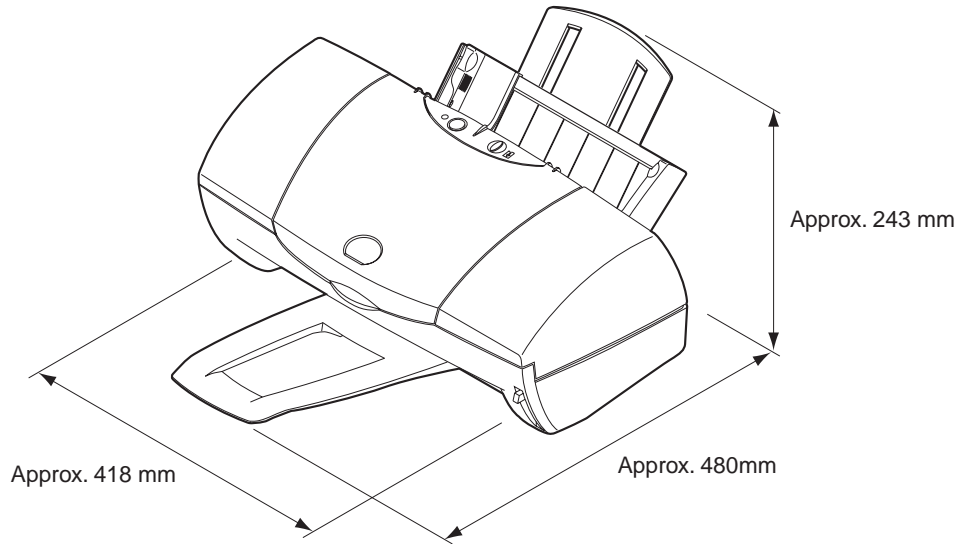

Product Specifications

Figure 1-6 Name of the Parts and Their Functions

6. PRODUCT CODE LIST

The product codes for the printer, consumables, and options are shown in *TABLE 1-1*.

TABLE 1-1 PRODUCT CODE LIST

Item		Name	Product code
Printer	-	BJC-3000 *	Q30-3180 Q30-3182
BJ cartridge	Black	BC-30	F45-1471
	Color	BC-33	F45-1491
	Photo	BC-34 Photo	F45-1511
Ink tank	Black	BCI-3BK	F47-2171
	Cyan	BCI-3C	F47-2181
	Magenta	BCI-3M	F47-2191
	Yellow	BCI-3Y	F47-2201
	Photo Black	BCI-3PBK Photo	F47-2231
	Photo Cyan	BCI-3PC Photo	F47-2211
	Photo Magenta	BCI-3PM Photo	F47-2221
Cartridge container	-	SB-30	Q70-4040
Scanner cartridge	-	IS-32	Q70-4070
Scanning holder for A4, LTR	Scanning Holder	SH-101	Q70-3640
	White Calibration sheet		

*: Packed with BJC-3000 are the BC-33/ BCI-3BK/ BCI-3C/ BCI-3M/ BCI-3Y/ SB-30.



Part 2

MAINTENANCE

Page	
2 - 1	1. REGULAR REPLACEMENT AND MAINTENANCE
2 - 1	1.1 Parts for Regular Replacement
2 - 1	1.2 Periodic Maintenance
2 - 2	2. DISASSEMBLY/REASSEMBLY
2 - 2	2.1 List of Tools
2 - 3	2.2 Disassembly/Reassembly Precautions
2 - 7	2.3 Disassembling and Reassembling the Printer
2 - 11	2.4 Grease Application
2 - 12	2.5 Adjustments and Settings after Disassembly/Reassembly
2 - 18	3. VERIFYING OPERATIONS AFTER DISASSEMBLY/REASSEMBLY
2 - 18	3.1 Methods
2 - 19	4. TRANSPORTING THE PRINTER
2 - 19	4.1 Preparation for Transportation

1. REGULAR REPLACEMENT AND MAINTENANCE

1.1 Parts for Regular Replacement

Level	Part
User	None
Service Personnel	None

Level	Consumable
User	Black BJ Cartridge: BC-30 Color BJ Cartridge: BC-33 Photo BJ Cartridge: BC-34Photo Black BJ Cartridge ink tank (Black: BCI-3BK) Color BJ Cartridge ink tank (Black: BCI-3BK, Cyan: BCI-3C, Magenta: BCI-3M, Yellow: BCI-3Y) Photo BJ Cartridge ink tank (Black: BCI-3BK Photo, Cyan: BCI-3C Photo, Magenta: BCI-3M Photo, Yellow: BCI-3Y)
Service Personnel	None

1.2 Periodic Maintenance

Level	Periodic Maintenance
User	None
Service Personnel	None

2. DISASSEMBLY/REASSEMBLY

2.1 List of Tools

Tools required for disassembly/reassembly are shown below:

Ordinary Tools	Use
Phillips screwdriver	For installing and removing screws
Blade screwdriver	For removing plastic parts
Long-nose pliers	For installing and removing coil springs
Tweezers	For installing and removing flexible cables
Flat brush	For applying grease
Multi-meter	For troubleshooting

Special Tools (Parts Number)	Use
Gap gauge 2.3mm (QY9-0054-000)	For adjusting the head gap (see Page 2-10 <i>Figure 2-12</i>). Qty: 1
Tension spring (QY9-0043-000)	For adjusting the carriage belt tension (see Page 2-14 <i>Figure 2-15</i>)
Grease MOLYKOTE PG-641 (CK-0562-000)	For application to the specified place (see Page 2-11 <i>Figure 2-13</i>)

2.2 Disassembly/Reassembly Precautions

2.2.1 Ink stain precautions (ink path/ink mist)

During servicing, do not touch the ink path as it can stain the printer, work table, hands, and clothing.

The ink path consists of the BJ cartridge's ink tank outlet, filter, nozzles, maintenance jet receiving section, head cap, wiper, and waste ink absorber.



Although the ink is non-toxic, it contains organic solvents.

Black ink:

Glycerin 56-81-5, diethyleneglycol 111-46-6

Yellow ink:

Glycerin 56-81-5, isopropyl alcohol 67-63-0

Cyan/Magenta/Photo-cyan/Photo-Magenta/Photo-black inks:

Glycerin 56-81-5, isopropyl alcohol 67-63-0, ethyleneglycol 107-21-1, diethyleneglycol 111-46-6.

Do not get ink in your eyes and mouth. If any ink gets in your eyes, wash with plenty of water and consult a doctor immediately.

If a large amount of ink is accidentally swallowed, consult a doctor immediately.

Since the ink contains dyes, any ink stains on clothing, etc., are permanent.

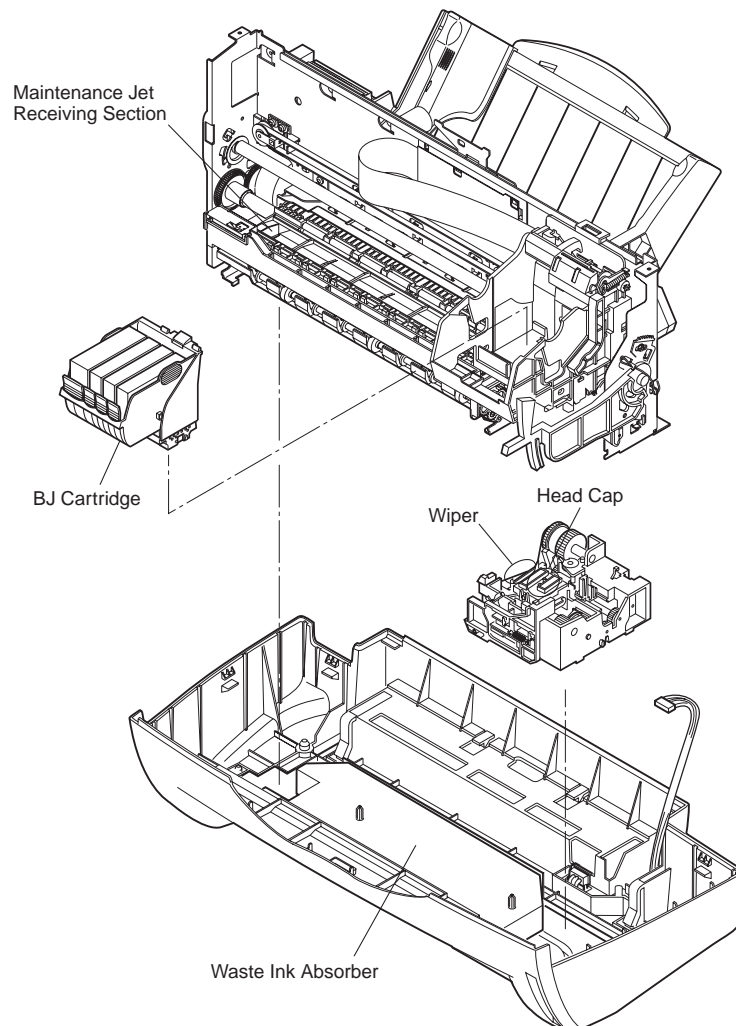

Figure 2-1 Ink Path

The BJ cartridge ejects ink onto the paper. Prolonged or heavy-duty use of the printer may cause ink mist (floating small amounts of ink mist splattering off paper) during printing, which will contaminate areas around the purge unit, the platen, and the front cover.

As ink mist can contaminate printing paper, and during servicing, hands and clothing, clean any contaminated parts with soft, moist cloth.

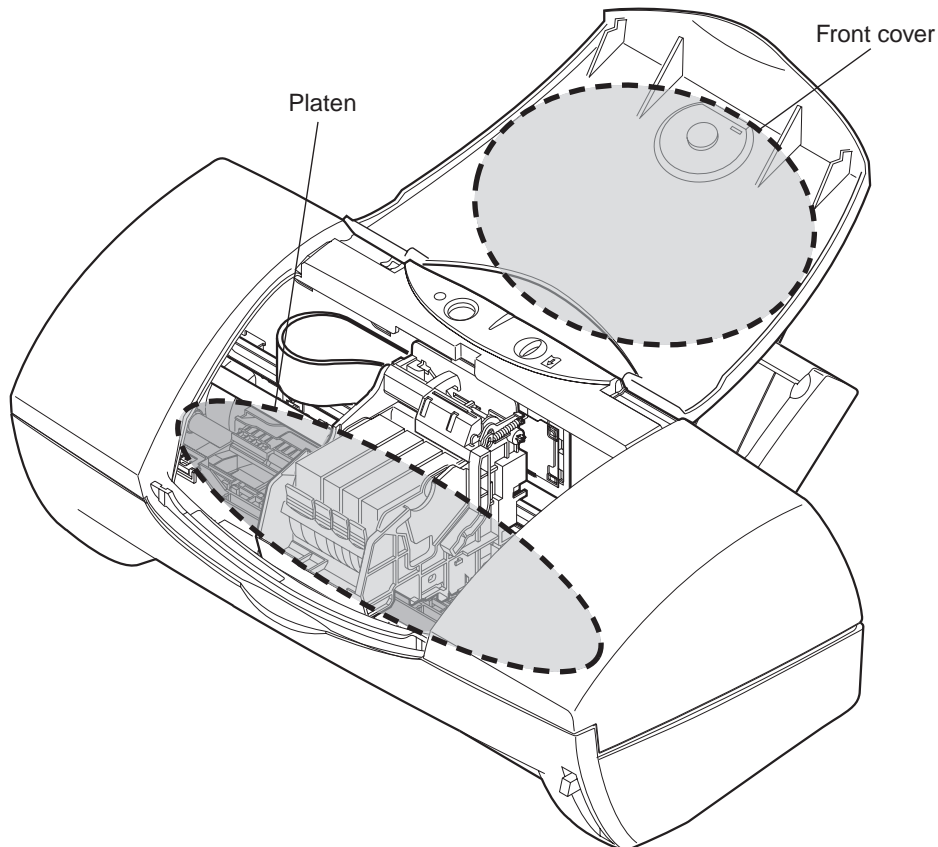

Figure 2-2 Ink Mist

2.2.2 Static electricity damage prevention

The static charge that accumulates from clothing, etc., can damage or change the electrical characteristics of electrical components. Never touch the electrical contact sections of the ink sensor and BJ cartridge.

2.2.3 Transportation precautions

To prevent print defects due to ink leakage and dried nozzles, keep the BJ cartridge stored in the BJ cartridge container when carrying or transporting the printer. Fix the carriage in the cartridge replacement position with tape before transportation, and fix the cartridge lock lever with carriage packing or tape.

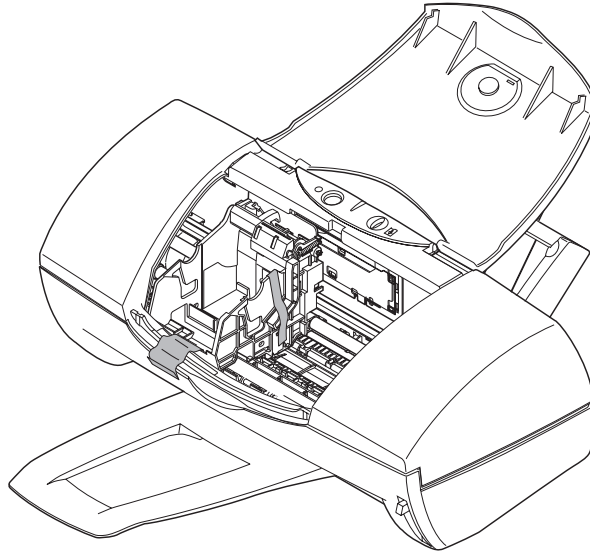

Figure 2-3 Transportation Precautions

2.2.4 Spur deformation precautions

Do not deform the tips of the spurs.

The spurs come into contact with the paper after printing. As the actual contact surface is small, any ink adhering to the spurs is minute and wiped off by the spur cleaners, and is not enough to contaminate the paper. However, if the spurs are deformed, their contact surface with the paper increases, causing more ink to adhere to each spur. Since the spur cleaner is unable to wipe off all the ink, a line of dotted ink may contaminate the printed paper.

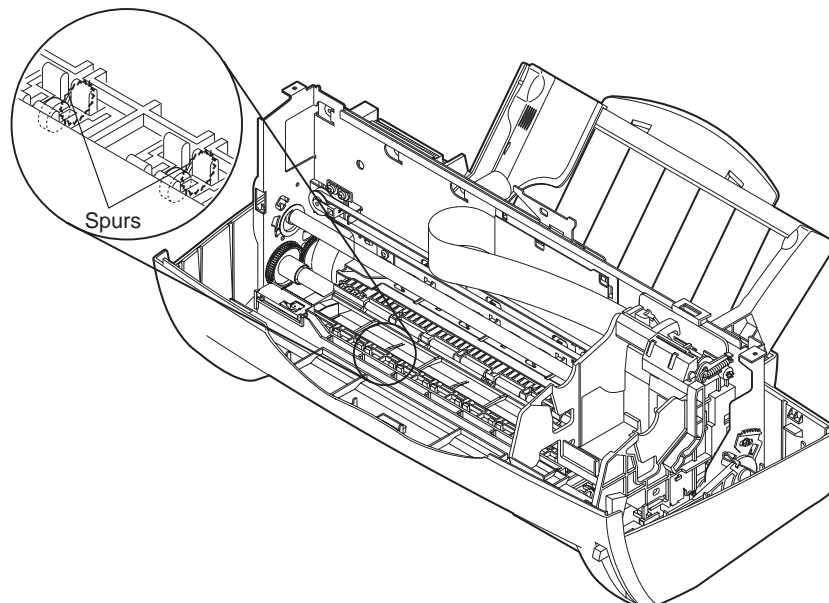

Figure 2-4 Spurs

2.2.5 Feed gear section precautions

Do not touch the gears of the paper feed unit, particularly the feed drive gear and the feed roller gear, during disassembly/reassembly. Even a minute scratch on the gears may result in irregular paper-feed during high-resolution printing.

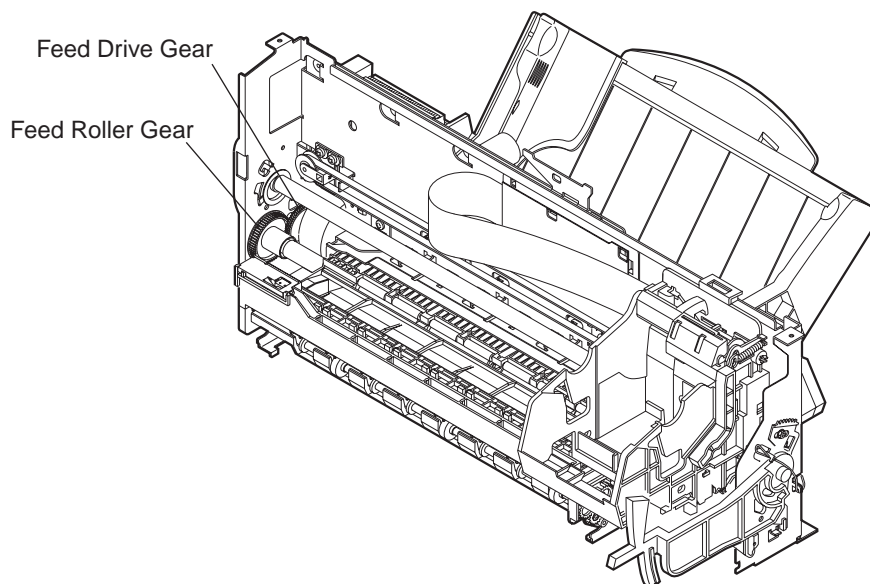

Figure 2-5 Feed Gear Section Precautions

2.3 Disassembling and Reassembling the Printer

Precautions during disassembly/reassembly are given below. Refer to the *Parts Catalog* for the disassembly procedures. In the *Parts Catalog*, illustration numbers are in the order of disassembly.

2.3.1 Carriage lock release

When the printer is properly turned off with a cartridge installed in the carriage, the carriage is locked in the carriage capping position.

When the printer can be turned on normally, the carriage will be unlocked. However, when the printer does not operate properly, it may be necessary to unlock the carriage manually. The carriage lock can be released by removing the cartridge and, while pressing the lever of the purge unit, moving the carriage toward the left.

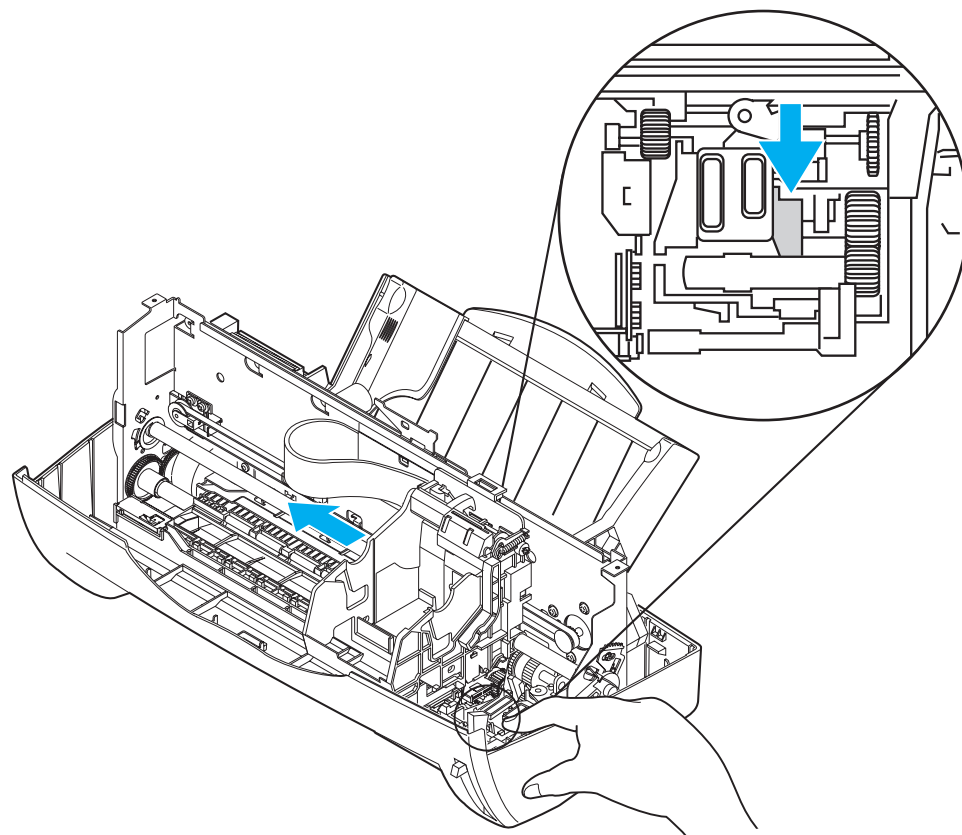

Figure 2-6 Carriage Lock Release

2.3.2 Removing tap screws

The printer unit and the base are attached with tap screws. Mold scrap from the tapping process may still be adhered to removed screws. Using those screws as-is may strip screw threads on the mold side. When reusing screws, remove the mold scrap completely or use a new screw.

2.3.3 Reattaching and removing the upper cover unit

Procedures to reattach the upper cover unit are shown below:

- 1) Assemble the back part of the upper cover unit.
- 2) Assemble the claw on the front side.

To remove the cover, follow the procedures in reverse order.

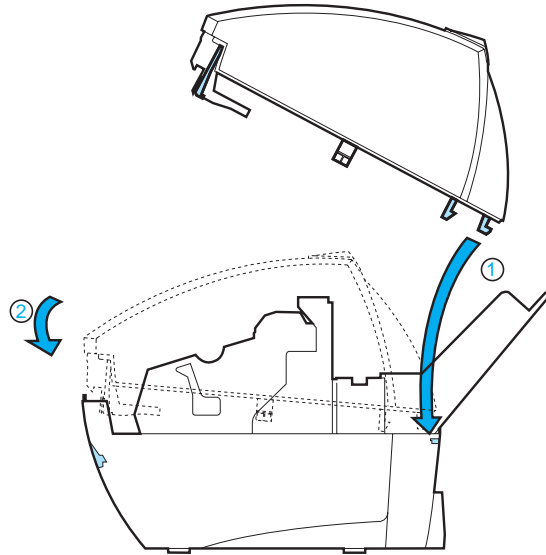

Figure 2-7 Reattaching and Removing the Upper Cover Unit

2.3.4 Removing the printer unit

Procedures to remove the printer unit are shown below:

- 1) Remove the screws which fasten the printer unit to the bottom case.
- 2) Release the 2 claws on the bottom case on the back side of the printer unit (Arrows 1 and 2).
- 3) Holding the handles on both sides of the printer, shift and raise the printer unit as by Arrow 3.

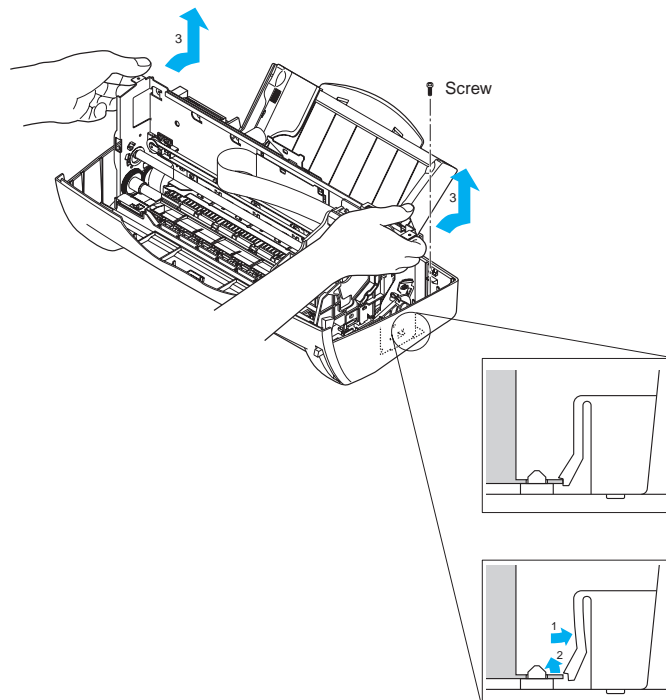

Figure 2-8 Removing the Printer Unit

2.3.5 Removing the pressure roller unit

To remove the pressure-roller unit, release the three claws in the order shown in the figure, and pull to the back side of the printer unit and remove.

Claws can be undone with ease when removed from the left side of the printer.

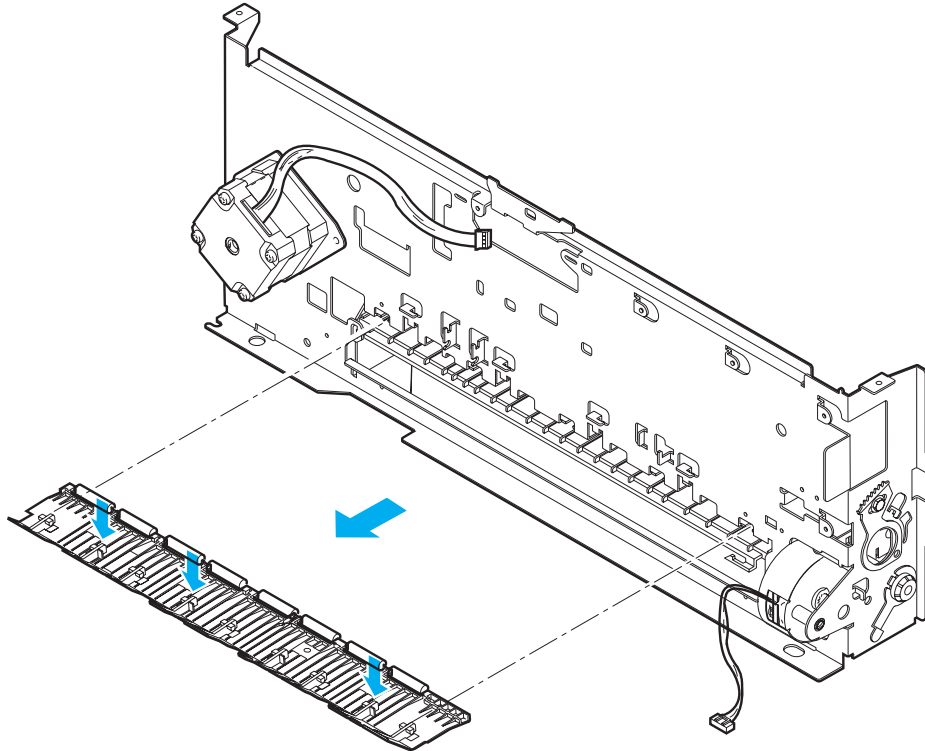

Figure 2-9 Removing the Pressure Roller Unit

2.3.6 Position of spurs in the spur base unit

The positions of spurs on the spur base unit are shown below (seen from the bottom, from which the spurs will be re-installed).

Re-install the spurs in the correct position if they are accidentally dislocated.

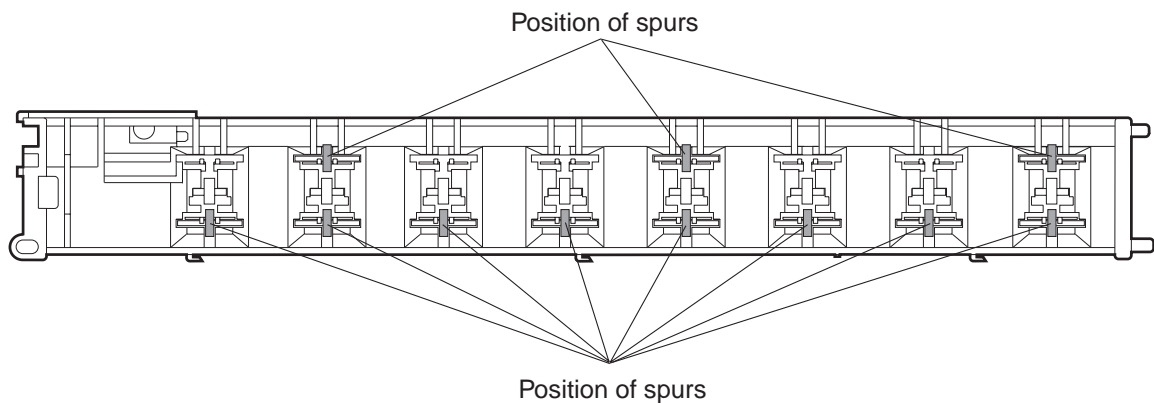

Figure 2-10 Position of Spurs in the Spur Base Unit (Bottom View)

2.3.7 Removing the ASF unit

The ASF unit is installed with the ASF drive gear and the pick-up roller matched in phase. When the ASF unit is removed from the printer frame, the ASF gear must be adjusted.

The fixing screws are painted red so that they are not loosened by mistake.

If the screws are loosened, adjust the gear position by following the instructions in 2.5.5 *When the ASF gear initial position adjustment is required* (Page 2-15).

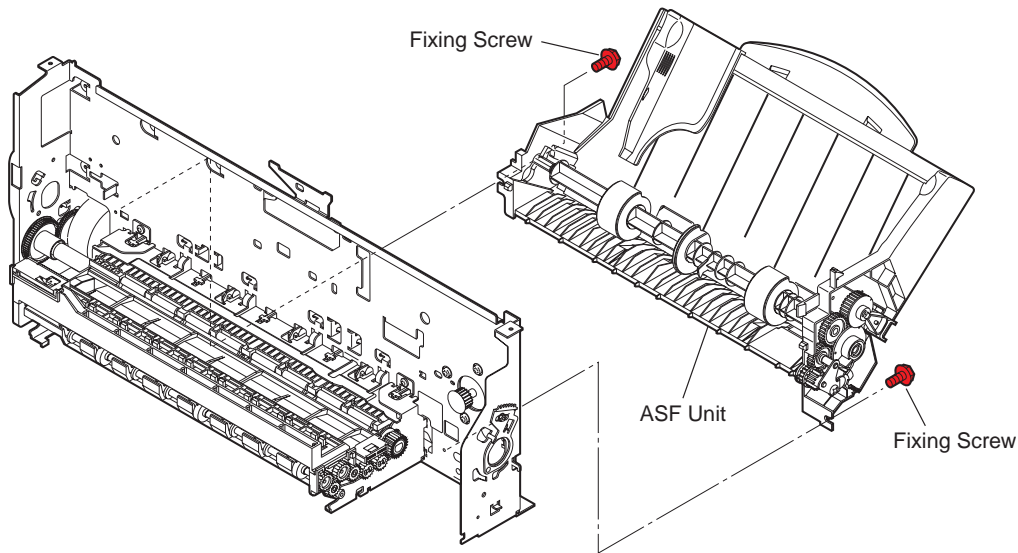

Figure 2-11 Removing the ASF Unit

2.3.8 Removing the head gap adjustment unit

The head gap adjustment boards are fixed to the printer frame and adjust the head gap between the nozzle head of the BJ cartridge and the platen to ensure high printing quality. When the fixing screws attaching the head gap adjustment boards to the printer frame have been loosened, it is necessary to adjust the head gap.

The fixing screws are painted red so that they are not loosened by mistake.

If the screws are loosened by mistake, adjust the head gap by following the instructions in 2.5.6 *When the head gap needs adjustment* (Page 2-16).

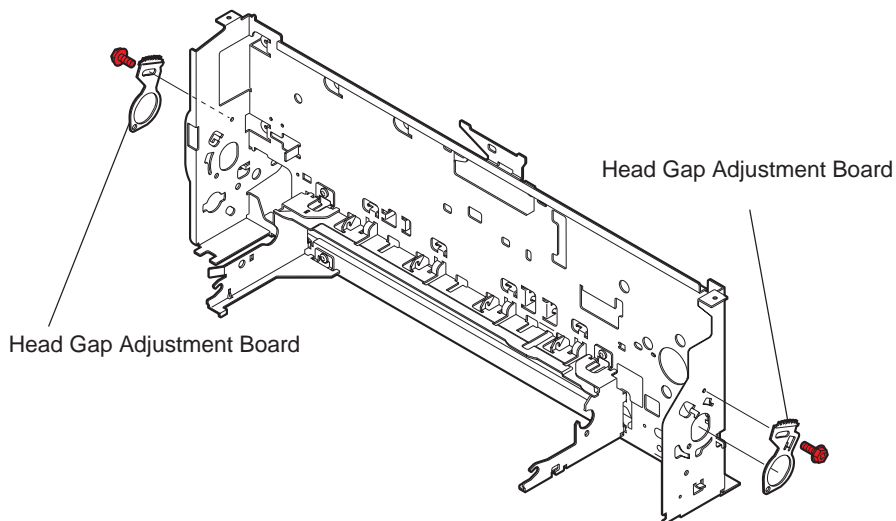

Figure 2-12 Head Gap Adjustment Board

2.4 Grease Application

This printer requires only 1 type of grease, MOLYKOTE PG-641 (CK-0562).
 The points to apply the grease are shown below.
 Use the flat brush to apply grease evenly.
 Refer to the *Parts Catalog* for disassembly/reassembly procedures.



Make sure that grease does not contact the wiper or the head cap.

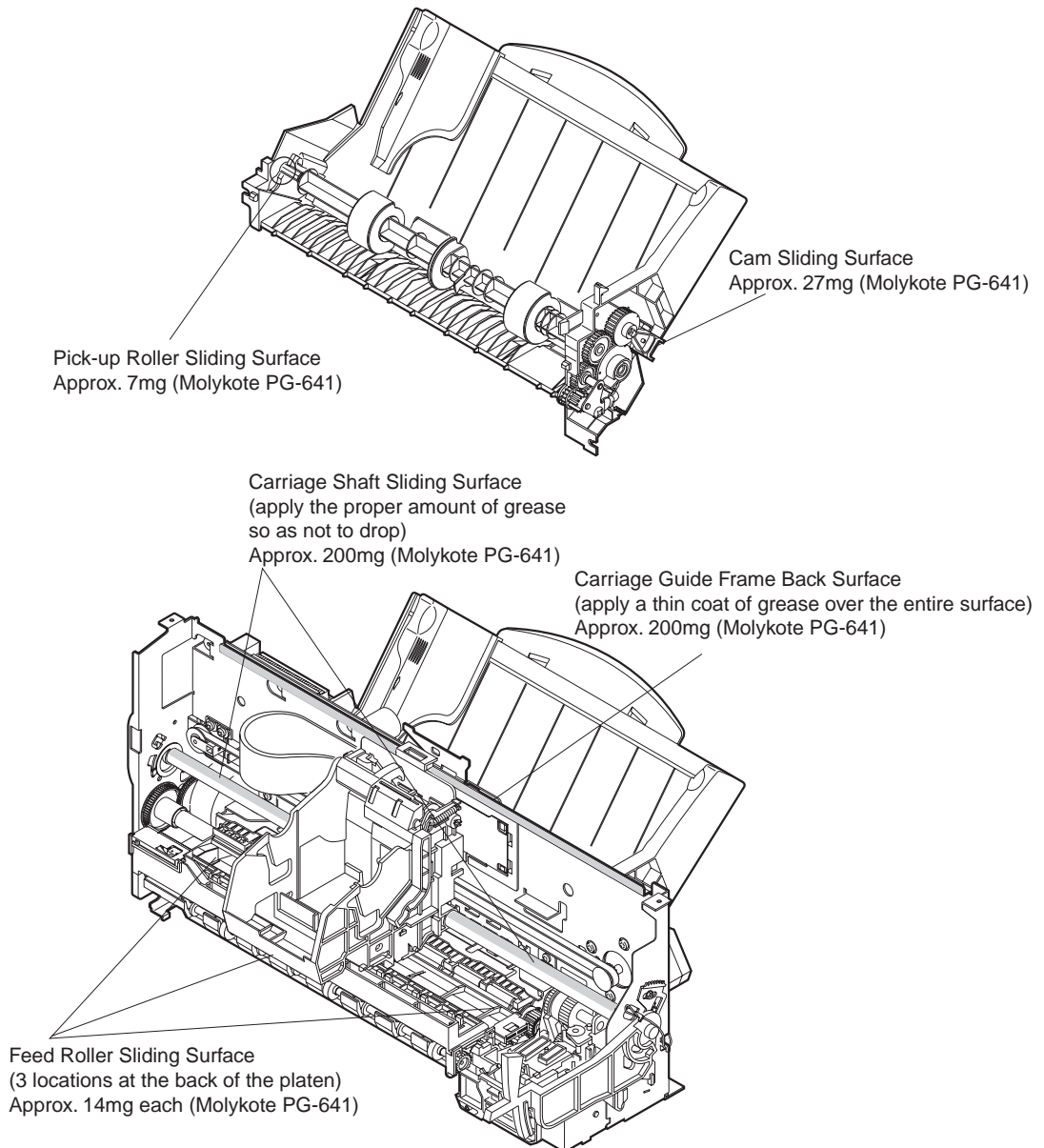

Figure 2-13 Grease Application Points

2.5 Adjustments and Settings after Disassembly/Reassembly

2.5.1 List of adjustment items

(Where adjustments are required/points/tools)

(1) User-level

Required	Adjustment Points	Time	Tools
BJ cartridge	BJ cartridge print position adjustment	2 minutes	One sheet of A4/LTR-sized paper

(2) Service Personnel-level

Required when	Adjustment Points	Time	Tools
Reinstalling the ASF	Initial positions of the ASF gear and the purge unit	1 minute	
Reinstalling the idler pulley	Belt tension	1 minute	Tension spring
Replacing the logic board and the waste ink absorber	EEPROM setting	1 minute	None
Removing and replacing parts related to the carriage	BJ cartridge print position adjustment	2 minutes	One sheet of A4/LTR-sized paper
Loosening the screws fixing the head-to-paper distance	Head gap	5 minutes	Gap gauge

2.5.2 When adjustment of the print head position is required

When replacing the print head, good print quality may not be obtainable due to changes in the dot placement points caused by the individual differences and the installation state of the BJ cartridge. To prevent this misalignment, use the printer driver utility to conduct the automatic head position adjustment after the BJ cartridge is installed. Set a sheet of A4/LTR-sized plain paper and perform the head position adjustment pattern in [Test print] in the printer driver's [Maintenance].

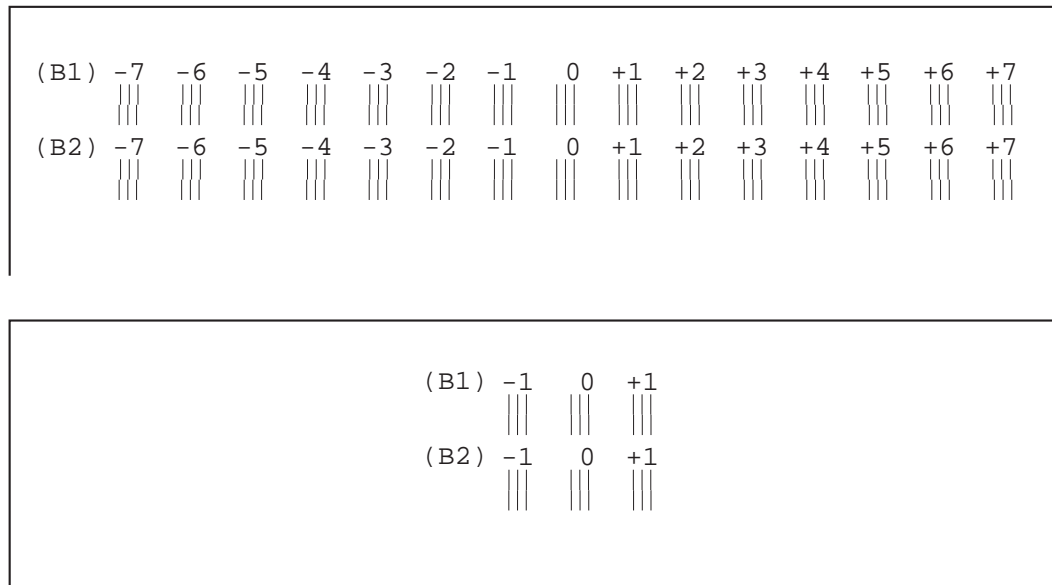

Maintenance

Figure 2-14 Print Position Adjustment Patterns



Be sure to set A4/LTR-sized paper in the ASF before printing the head position adjustment pattern. Using printing paper smaller than the printing area of the data when performing the head position adjustment print will contaminate the platen with ink.

2.5.3 When EEPROM setting is required

Replacing the control board and the waste ink absorber requires resetting the EEPROM, setting the model, and confirmation with the test printout.

The EEPROM (IC502) keeps track of data that is native to the machine, including the waste ink amount and the model settings.

Refer to *Part 3: 2.1 Service Mode Operations* (Page 3-8) for the operation procedures.

(1) After Control Board Replacement

When replacing the control board, the waste ink absorber must also be replaced if the waste ink amount exceeds 7%. Also, the EEPROM needs to be reset and model setting must be performed.

Confirmation of the waste ink amount can be carried out with the service/factory test print before replacing the control board, or by visually checking the waste ink absorber.

The memory data for the replacement control board (EEPROM) is not defined.

If the EEPROM is not reset, the waste ink level may exceed the waste ink absorber capacity without causing the waste ink full error.

(2) After Waste Ink Absorber Replacement

Reset the EEPROM's total waste ink amount to zero.



After the EEPROM is reset, the data it contained cannot be confirmed with the test printout. Be sure to check the stored data before resetting the EEPROM.

When the stored data is reset, the various settings, such as the total count of sheets passed, and the total waste ink amount will be reset, however, the model setting will remain.

Data on the EEPROM before replacement, including various settings and the total waste ink amount, cannot be written to the new EEPROM.



When the waste ink-full error occurs, it can be assumed that the printer has printed more sheets than its service life called for. However, this depends on how many times the power has been turned on/off, the cartridge has been replaced (the number of times the front cover is opened), and the usage conditions.

2.5.4 When the carriage belt tension needs adjustment

When tension on the carriage belt has been loosened, for example, to remove the carriage, the carriage belt tension needs to be adjusted.

Use the tension spring tool (QY9-0043) when fixing the pulley assembly before tightening the screws. Remove the tension spring after the screws are fixed.

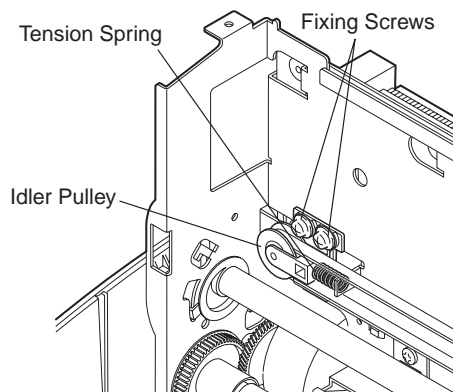

Figure 2-15 Carriage Belt Tension Adjustment

2.5.5 When the ASF gear initial position adjustment is required

When installing the ASF, the ASF gear initial position adjustment must be executed to match phase with the purge unit's ASF drive gear, which is the transmission source of the ASF drive, and the ASF gear.

Preparing for the Adjustment:

Make sure that the purge unit's ASF drive gear is in the initial position when assembling. If it is in the initial position, assemble the printer with the ASF unit removed, and Procedures 1) through 3) are not necessary. If it is not in the initial position, follow the adjustment procedures described below.

- 1) Manually rotate the ASF drive gear slowly in the direction of the arrow to move it to the initial position.
- 2) Stop rotating the gear until a click can be felt (where the rotation stops).
(To confirm the position, gently move the ASF drive gear vertically with your fingers. Make sure that the gear is at the position where click can be felt.)
- 3) If the gear has passed the click position, rotate the gear in the arrow's direction to return to the correct position.

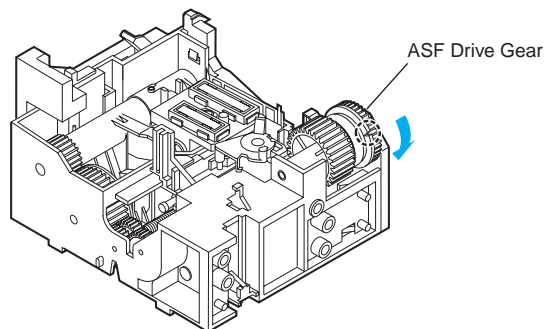

Figure 2-16 ASF Drive Gear Initial Position

Adjustment Procedures

- 1) Rotate the pick-up roller to place the ASF unit's cam and the mark in the position shown in *Figure 2-17*.
- 2) Hold the gear still with your fingers and fix the ASF unit to the printer chassis by screw. Align the projection of the ASF gear with the indentation of the ASF drive gear. Placing the hooks on the upper side of the ASF and slowly swinging the ASF down will ease the installation.
- 3) Fix the ASF unit to the printer chassis with screws to keep the adjusted gear position.

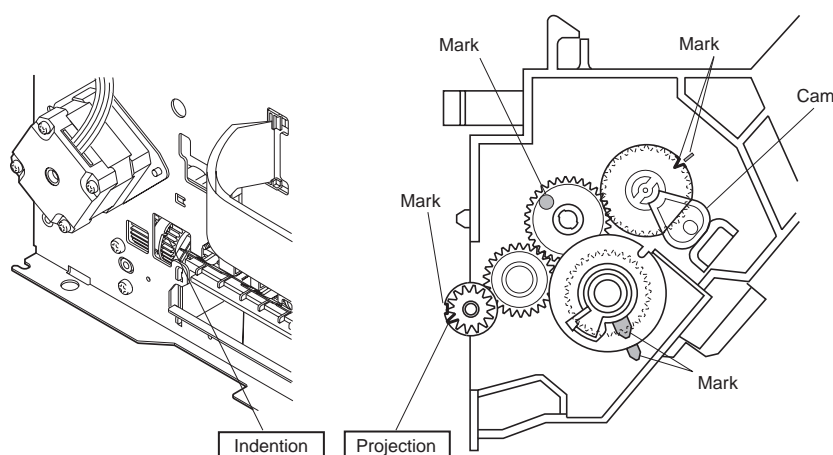

Figure 2-17 ASF Gear Initial Position Adjustment

2.5.6 When the head gap needs adjustment

The head gap needs to be adjusted when the screws fixing the head gap adjustment boards to the printer frame have been removed or loosened.

Preparing for the Adjustment

- 1) Remove the upper cover unit and the bottom case. (Or, assemble the upper cover unit and the bottom case to the point they are ready to be installed)
- 2) Remove the paper selector lever spring and the shaft clips on the left and right, and reinstall the bottom case.
- 3) Loosen the red fixing screws on both sides of the printer chassis by a half-turn from the fixed position.
- 4) Lower the paper selector lever to the thick paper position.



Make sure that the gap gauge is not deformed and no foreign matter is attached to the gap gauge or the platen before performing the adjustment.

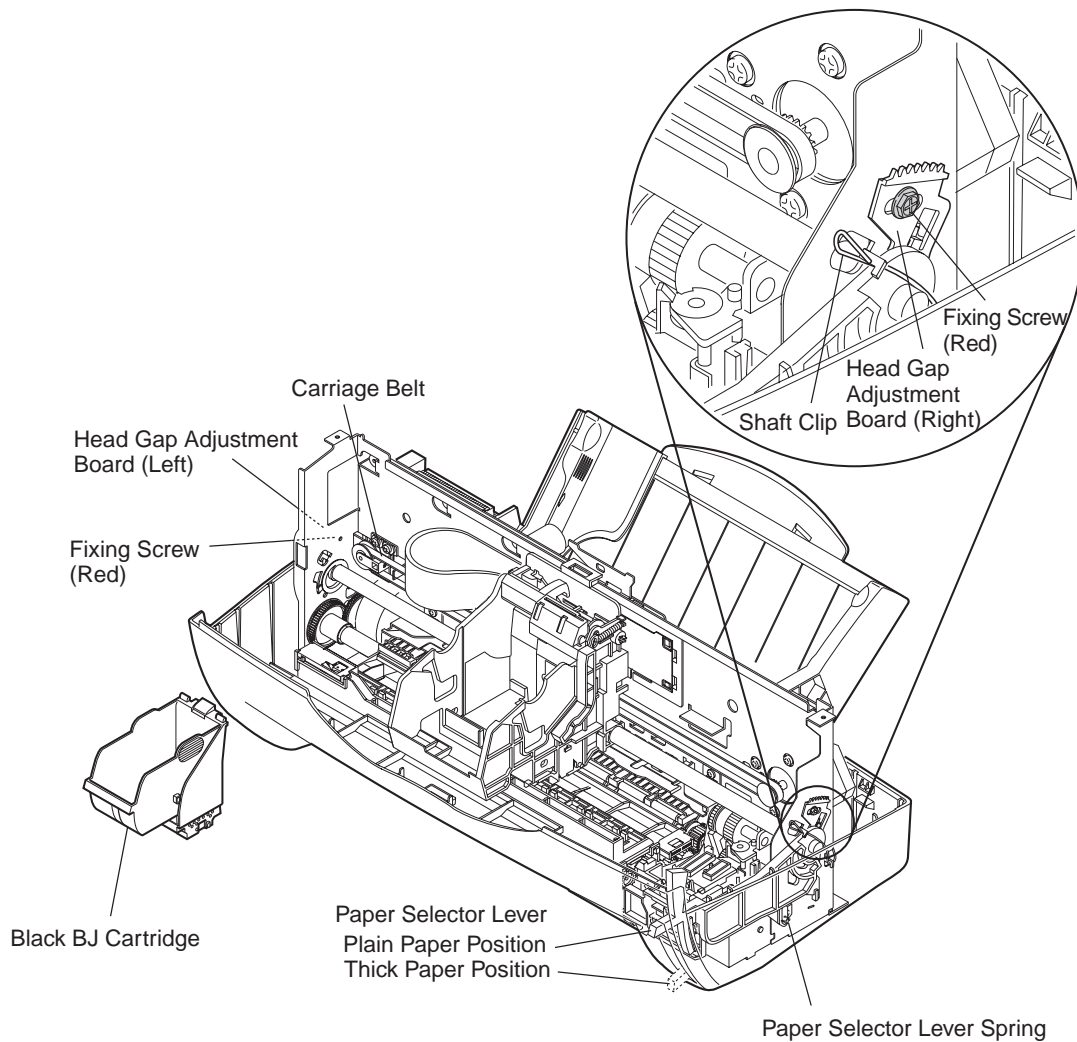

Figure 2-18 Head Gap Adjustment 1

Adjustment Procedures

- 1) Place the gap gauge (QY9-0054) in Position A1.
- 2) Move the carriage belt manually to bring the carriage to Position A2. Align the right edge of the carriage with the bottom case's rib.
- 3) Install a black BJ cartridge with no ink tank in the carriage.
- 4) Move the paper selector lever up and down 2 or 3 times, and then, with the lever raised in the plain paper position, tighten the right fixing screw.
- 5) Remove the black BJ cartridge.
- 6) Set the gap gauge in Position B1.
- 7) Lower the paper selector lever to the thick paper position. (down)
- 8) Move the carriage belt manually and bring the carriage to Position B2. Align the left edge of the carriage with the edge of the ink sensor's cover.
- 9) Install a black BJ cartridge with no ink tank in the carriage.
- 10) Move the paper selector lever up and down 2 or 3 times, and then, with the lever raised in the plain paper position, tighten the left fixing screw.
- 11) Remove the black BJ cartridge.
- 12) Loosen the right fixing screw by a half-turn, and execute procedures 1 through 5 again to complete the adjustment.

Remove the bottom case again to attach the paper separator lever spring and the shaft clips on both sides.

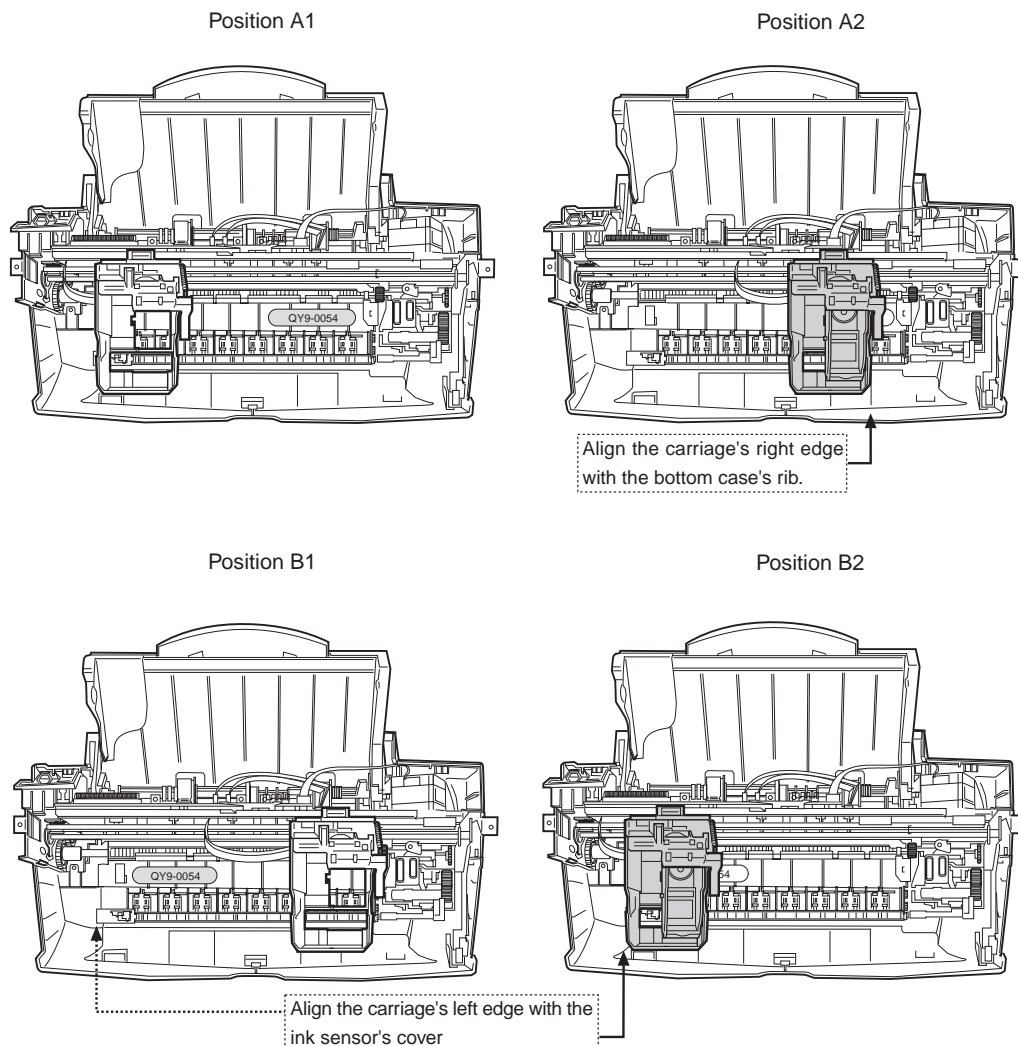

Figure 2-19 Head Gap Adjustment 2

3. VERIFYING OPERATIONS AFTER DISASSEMBLY/REASSEMBLY

3.1 Methods

To confirm the operation of the printer after disassembly/reassembly, follow the procedures below:

Service/Factory Test Print

Confirms the normal printing. Refer to *Part 3: 2.1 Service Mode Operations* (Page 3-8).

If the control board or the waste ink absorber have been replaced, the following confirmations must be made in addition:

Replacement of the Control Board	ROM version/machine name is to be correct on the service/factory test printout, and the amount of sheets passed and the total waste ink absorbed are to be cleared. The nozzle check pattern can be printed using the printer driver.
Replacement of the Waste Ink Absorber	Total amount of the waste ink absorbed is to be cleared on the service/factory test printout.

4. TRANSPORTING THE PRINTER

To prevent ink leakage and defective printing due to dried nozzles, keep the BJ cartridge (with ink tanks installed) stored in the BJ cartridge container when carrying or transporting the printer.

Fix the carriage in the cartridge replacement position with tape for transportation.

4.1 Preparation for Transportation

Prepare for transportation by following the instructions described below:

- 1) Open the front cover while the power is turned on. The carriage will move to the cartridge replacement position.
- 2) Remove the cartridge from the carriage and put it in the container.
- 3) Turn off the printer by pressing the *POWER* button.
- 4) Disconnect the interface cable.
- 5) Remove the AC power plug from the outlet.
- 6) Fix the carriage in the cartridge replacement position with tapes.
Fix the cartridge lock lever with tapes as well.
- 7) Close the front cover.
- 8) Pack the printer in its' original packaging. If the original packaging is not available, pack the printer in sufficient shock-absorbing material.

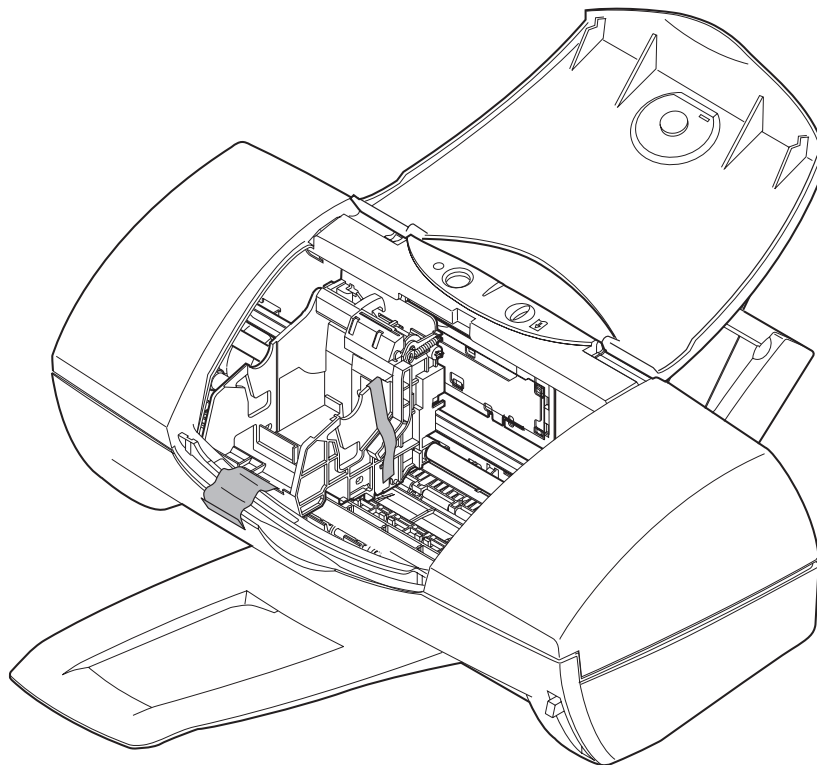

Figure 2-20 Transporting the Printer

This page intentionally left blank.



Part 3

OPERATION

Page	
3 - 1	1. FUNCTIONS RELATED TO PRINTER OPERATION
3 - 1	1.1 Status Indications
3 - 5	1.2 Operations from the Computer
3 - 6	1.3 Operations from the Printer
3 - 8	2. SERVICE FUNCTIONS
3 - 8	2.1 Service Mode Operations
3 - 9	2.2 Service/Factory Test Print
3 - 10	2.3 EEPROM Information Print
3 - 11	2.4 Resetting the EEPROM
3 - 11	2.5 Model Settings with EEPROM
3 - 11	2.6 Ink Presence Check
3 - 11	2.7 Power Off/Carriage Lock

1. FUNCTIONS RELATED TO PRINTER OPERATION

This printer has built-in functions to provide status indications, operation from the computer, and operation from the printer itself.

1.1 Status Indications

The indicator shows the status of the printer. In particular, errors are indicated on the printer itself, by the combination of blinks in orange and in green.

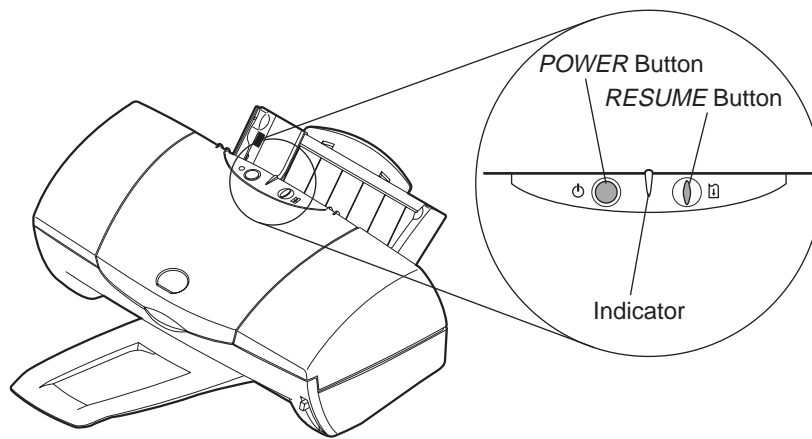

Figure 3-1 Operation Panel

1.1.1 Status indications by the LED

Status indications by the LED are described below.

TABLE 3-1 STATUS INDICATIONS BY THE LED

Indicator Status	Status
Green (lit)	Powered-on
Green (blinking)	Power-on in progress, power-off in progress, resetting, cleaning, test printout in progress, front cover open, printout in progress.
Light off	Powered-off

Errors:

Recoverable by Users

The indicator blinks in orange the number of times that corresponds to the error type, followed by an extended blink in green. This procedure is repeated.

Unrecoverable by Users

The indicator blinks alternately in orange and in green the number of times that corresponds to the error type, followed by an extended blink in green. This procedure is repeated.

Error Conditions	Indicator Blinks	Error Codes*	Reference Pages
<i>[Recoverable by Users]</i>			
Paper feed error	2 times in orange	...	Page 4-12
Paper jam error	3 times in orange	...	Page 4-12
Ink out error	4 times in orange	...	Page 4-14
Mis-installed Cartridge error	5 times in orange	...	Page 4-15
No cartridge error	6 times in orange	...	Page 4-15
Cartridge error	7 times in orange	...	Page 4-15
Waste ink warning**	8 times in orange	...	Page 4-5
<i>[Unrecoverable by Users]</i>			
ROM error	1 time in orange/green	...	Page 4-5
RAM error	2 times in orange/green	...	Page 4-5
EEPROM error	3 times in orange/green	6800	Page 4-5
Home position error	4 times in orange/green	5100	Page 4-6
Temperature sensor error	5 times in orange/green	5400	Page 4-5
Waste ink full error	6 times in orange/green	5B00	Page 4-5
Head temperature error	7 times in orange/green	5200	Page 4-9
Head temperature sensor error	8 times in orange/green	5200	Page 4-9
Cartridge displaced error	9 times in orange/green	5600	Page 4-10
ASF sensor error	10 times in orange/green	5700	Page 4-11
<i>[Internal Error]</i>			
Ink sensor error***	None	...	Page 4-16

* : Error codes are displayed on the computer. When the printer is connected to iMac or Power Macintosh G3, "D" or "M" is prefixed to an error code.

** : Waste ink warning can be canceled by pressing the *RESUME* button.

*** : Internal errors are not displayed. Errors can be confirmed with *Part 3: 2.3 EEPROM Information Print*. (Page 3-10).

1.1.2 Details of error conditions

Recoverable by Users

1. Paper feed error:

Paper cannot be fed even after paper-feed operation is performed.

2. Paper jam error:

Paper cannot be ejected even after performing the ejection operation for 23 inches.

3. Ink out error:

Ink in the applicable ink tank is empty within the ink tank and sponge part.

4. Mis-installed cartridge error:

The installed cartridge (BJ cartridge or scanner cartridge) is not for the intended printing or scanning operation.

5. No Cartridge error:

Cartridge is not installed.

6. Cartridge error:

Cartridge is defective.

7. Waste ink warning:

The total waste ink amount (stored in EEPROM) exceeds 95% of the defined capacity.

Unrecoverable by Users

8. ROM error:

ROM checking during initialization is NG.

9. RAM error:

RAM checking during initialization is NG.

10. EEPROM error:

Writing to EEPROM has failed

11. Home position error:

Irregular home position sensor (broken circuit), or the home position of the carriage cannot be detected.

12. Temperature sensor error:

The temperature sensor on the control board (TH501) is irregular (broken circuit, etc.).

13. Waste ink full error:

The total waste ink amount (stored in EEPROM) exceeds the defined capacity (100%).

14. Head temperature error:

The temperature in the BJ cartridge is irregular. This error invariably occurs before head temperature sensor error.

15. Head temperature sensor error:

The temperature sensor of the BJ cartridge head is irregular.

16. Cartridge displaced error:

The printer cannot detect the cartridge when the carriage is out of the cartridge replacement position.

17. ASF sensor error:

The pick-up roller does not rotate during sheet-feed operation, or the pick-up roller flag cannot be detected by the pick-up roller sensor.

18. Ink sensor error:

Ink is detected to be present even when there is none during the initial ink sensor check.

The ink detection operation is only conducted at AC power on, and ink in the ink tank is invariably detected to be present.

1.1.3 BJ status monitor

The BJ status monitor indicates the status of the printer and printjob progress. It also enables the user to cancel printing operations.

(1) Major Functions of the BJ Status Monitor

- 1) Displays the present printer status and printjob progress with diagrams and messages, in real time.
- 2) Displays the types of error and simple recovery methods.
- 3) Displays the type of BJ cartridge installed and ink out warnings with names and icons.
- 4) Cancels the printjob in progress.

(2) Items Indicated on the BJ Status Monitor

- 1) Printer name:
- 2) Document name:
- 3) Status: (Error codes and simple measures also appears during error)
- 4) Printout starting date and time:
- 5) Progress status:
- 6) Number of pages printed:
- 7) Cancel printout:
- 8) Installed cartridge: (type of BJ cartridge and the ink-out warnings are indicated with icons)

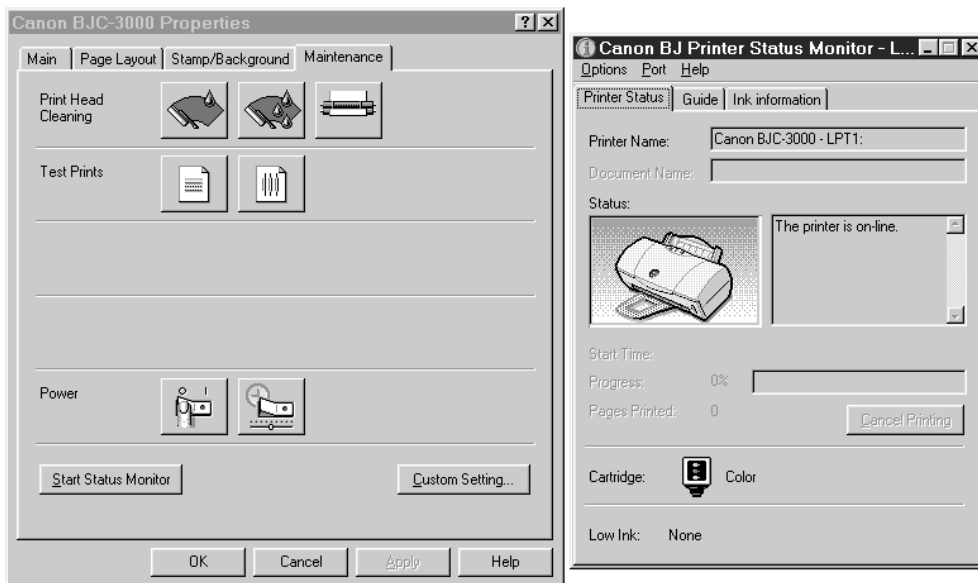

Figure 3-2 Status Monitor (Sample)

1.2 Operations from the Computer

The functions of this printer can be set up using the printer driver.

1.2.1 Function settings using the printer driver

The following items can be set up and performed with the driver's Maintenance sheets:

- 1) Cleaning
- 2) Head refreshing
- 3) Pick-up roller cleaning
- 4) Nozzle check pattern print
- 5) Head position adjustment
- 6) Power off
- 7) Automatic power settings
- 8) Open status monitor
- 9) Custom settings
 - Set the printer to ECP mode (factory default: disabled)
 - High-speed printing (factory default: enabled): Printer response time (ACKNLG) changes from 4ms to 0.9ms.
 - Pause page (factory default: disabled)
 - Pause scan (factory default: disabled)

<<User-specific special menu (user-specific and service modes)>>

Selecting Custom Setting while pressing the *Shift* key will display the user-specific special menu.

- **Economy cleaning (disabled by default)**

Disables the cleaning operations performed during the initial power-on after the AC power input. This reduces the amount of ink consumed during service, or when the printer is connected to the computer's interlocking power. However, this function is disabled if at least 72 hours has lapsed from AC power input to power-on.

- **Smear control (enabled by default)**

Disables the smear control performed to prevent ink smearing during high-duty printing on plain paper using the black BJ cartridge. By disabling the smear-control and removing the ejected sheets one by one, throughput increases.

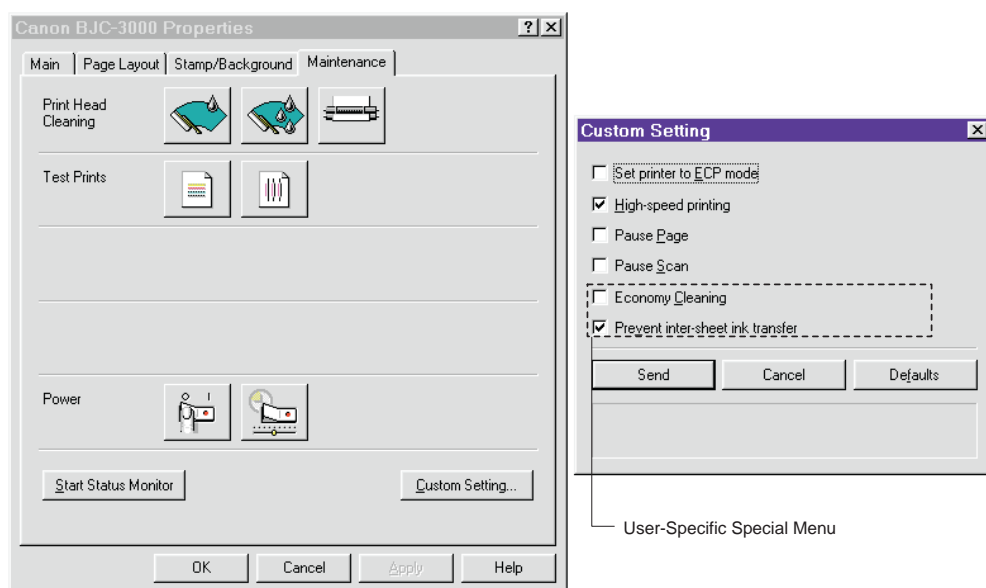

Figure 3-3 Printer Driver Utility (Sample)

1.3 Operations from the Printer

This printer has offline operations which can be performed independent of the computer.

Press and hold the *RESUME* button while the power is turned on. Release the *RESUME* button after the green indicator has blinked the appropriate number of times to start the specified operation.

Actions	Indicator Waver Frequency	Note
Cleaning	1 time	---
Nozzle check pattern print	2 times	Completed after printout
Roller cleaning	3 times	Ejects one cleaning sheet
---	4 times	No action

1.3.1 Cleaning

While the power is turned on, press and hold the *RESUME* button and release it after the green indicator has blinked once to execute the cleaning action. This can also be performed from the printer driver [Maintenance] by connecting the printer to a computer.

1.3.2 Nozzle check pattern print

While the power is turned on, press and hold the *RESUME* button and release it after the green indicator has blinked twice to execute the nozzle check pattern print. In the event that print defects appear, perform cleaning operations on the BJ cartridge. If print quality does not improve, even after the cartridge is cleaned five times, replace the BJ cartridge.



The nozzle check pattern print requires A4/LTR-size paper. Using smaller sized paper will result in parts of the printout being printed directly on the platen.



To cancel the test print, press the *POWER* button. The printer will power off after ejecting the test print.

1.3.3 Roller cleaning

While the power is turned on, press and hold the *RESUME* button and release it after the green indicator blinks three times to execute the roller cleaning. It ejects the cleaning sheet set in the auto sheet feeder and cleans paper dust from the pick-up roller and paper-feed roller.

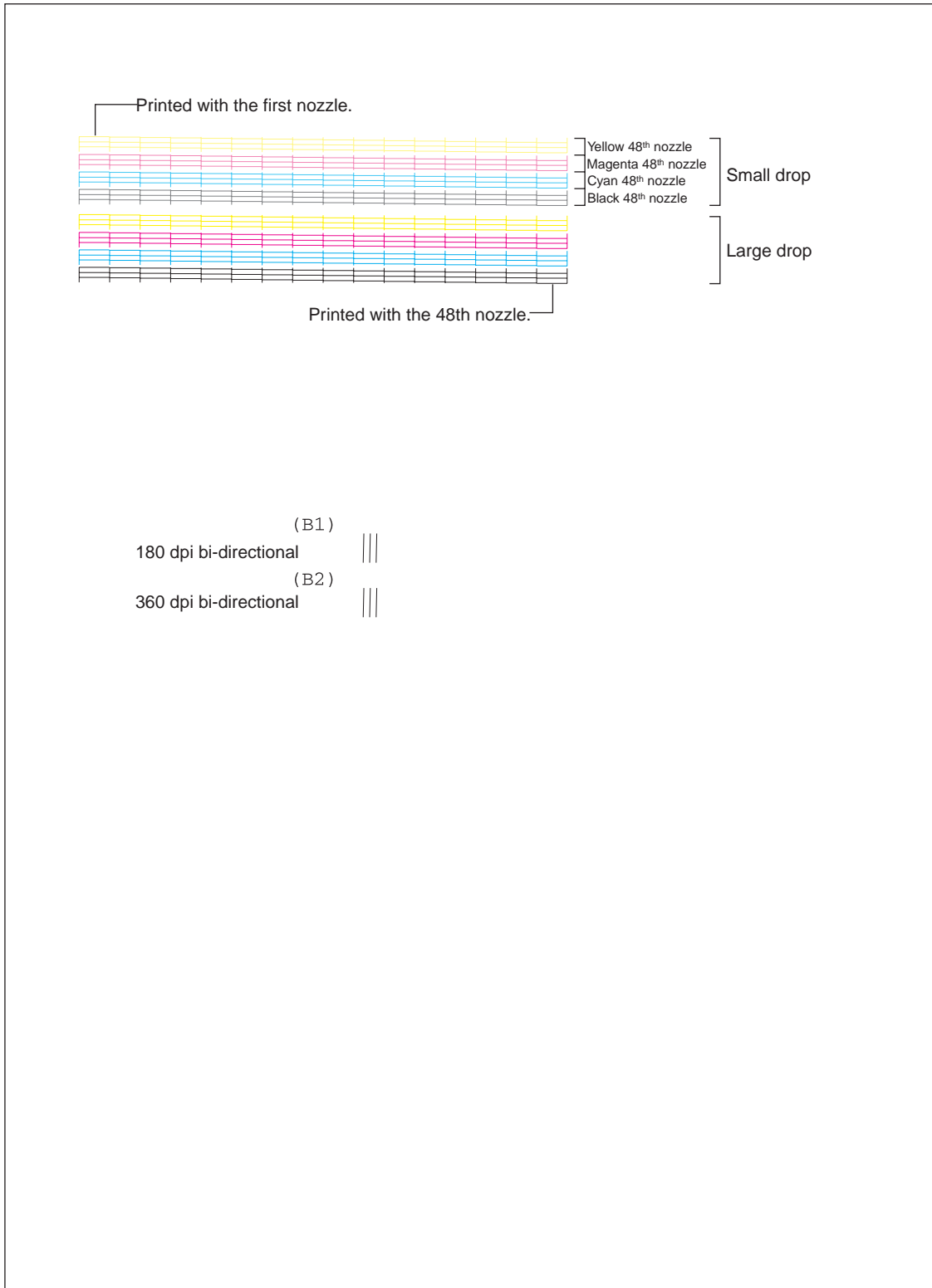

Figure 3-4 Nozzle Check Pattern Print (Color Sample)

2. SERVICE FUNCTIONS

This printer provides a service mode to output a test printout, to set up and confirm the service. Button operation is used to switch to this mode.

2.1 Service Mode Operations

- 1) When the power is turned off, while holding down the *RESUME* button, press and hold the *POWER* button. The green indicator will light up.
- 2) While holding down the *POWER* button, release the *RESUME* button. Then double-click the *RESUME* button and release the *POWER* button.
(The indicator blinks in orange/green every time the *RESUME* button is pressed.)
- 3) The green indicator blinks while initial operations are in progress. When the indicator lights (stops blinking), press the *RESUME* button to select one of the followings.
(The indicator blinks in orange/green every time the *RESUME* button is pressed.)

Press	Indicator	Functions
0 times	Lights in Green	Service/factory test print
1 time	Lights in Orange	EEPROM information print
2 times	Lights in Green	EEPROM initialization (Clears the settings to the factory default, except the model settings)
3 times	Lights in Orange	Waste ink counter reset
4 times	Lights in Green	Model setting *: for details, see below
5 times	Lights in Orange	Ink presence check; Readout data print
6 times or more	Lights in Orange	Power off/carriage lock

- 4) Execute the function you have selected by pressing the *POWER* button. The indicator will light in green, and the operation will be executed.
(The printer will turn off after the operation has completed.)

* : If Model setting is selected, the *RESUME* button is to be pressed the appropriate number of times shown below.
(The green indicator blinks during the initial operation. The indicator will light in orange/green every time the *RESUME* button is pressed.)

Press	Indicator	Model
0 time	Lights in Green	BJ F300
1 time	Lights in Orange	BJC-3000
2 times or more	---	Reserved (setting will not change).

After making your selection, press the *POWER* button to enable the new setting.
(The printer will turn off when the operation is completed.)



Be sure to install a BJ cartridge prior to operations in the service mode, as it is not possible to enter service mode otherwise. Confirm the model settings with the service/factory test print if they have been changed.

2.2 Service/Factory Test Print

In the service/factory test print, the control ROM version, model setting, total number of pages passed with each cartridge, and total amount of waste ink are indicated in the header.

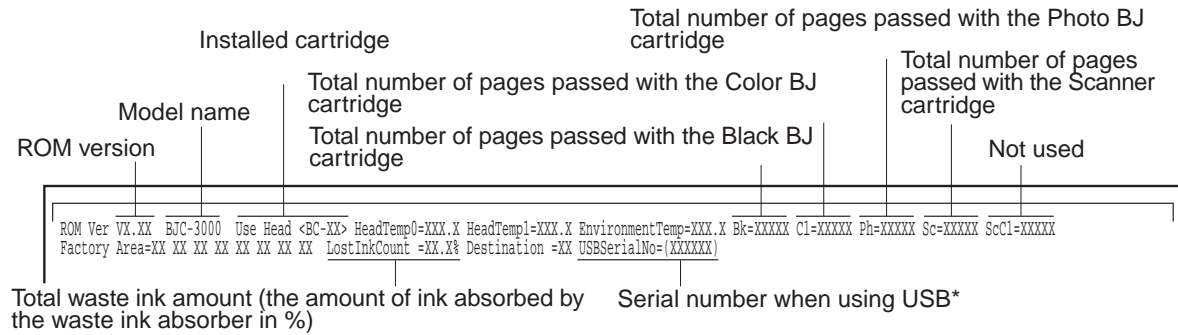

Figure 3-5 Service/Factory Test Printout (Sample)

*** : USB Serial Number**

A USB serial number will be assigned, in conformance with USB standards, so that each printer can be identified when multiple printers are connected to a host computer via USB interface.

A unique value is recorded in the EEPROM when the control board is manufactured. The USB serial number recorded in the EEPROM will not be cleared even when the EEPROM is reset. Also, it cannot be overwritten with any value.



2.3 EEPROM Information Print

The EEPROM records various settings, the data on the total number of sheets passed with the Black/Color/Photo BJ cartridges and Scanner cartridge, the total waste ink amount, and data on the past three user-unrecoverable errors. The EEPROM data recorded in the EEPROM will be printed out in hexadecimal dump format. The data recorded in the EEPROM may serve as a reference for how much the printer has been used.

```

- EEPROM Information <Hex.> -
Address  +0 +1 +2 +3 +4 +5 +6 +7 +8 +9 +A +B +C +D +E +F
00000000  20 03 0B 00 02 06 00 00 80 BA 0B 00 00 00 00 00
00000010  C8 AE 11 09 78 8F 07 23 18 BD D2 20 D2 C4 52 20
00000020  00 00 00 00 00 00 00 00 00 00 00 00 00 00 00
00000030  00 00 00 00 00 00 00 00 00 01 00 00 02 00 00
00000040  00 00 00 00 92 00 00 00 C8 00 00 00 C4 04 00 00
00000050  B8 07 00 00 11 00 00 00 00 00 07 00 00 00 00
00000060  00 00 02 00 00 00 00 00 01 00 00 00 00 00 00
00000070  00 00 00 00 00 00 00 00 00 00 00 00 00 00 00
00000080  00 00 00 00 00 00 00 00 00 00 00 00 C1 00 00
00000090  3C 00 00 00 00 00 00 00 00 00 00 00 00 00 00
000000A0  00 00 00 00 00 00 00 00 00 00 00 00 00 00 00
000000B0  00 00 00 00 00 00 00 00 00 00 31 30 48 45 54 33
000000C0  00 00 00 00 F0 F1 68 81 9E 9F 94 53 F6 70 8C 57
000000D0  EC 87 8C EE 00 00 00 00 E6 E3 EA 12 1C F3 11 95
000000E0  00 00 00 00 00 00 00 00 00 00 00 00 00 00 00
000000F0  00 00 00 00 00 00 00 00 00 00 51 41 01 00 97 15

```

Error Record 1
Error Record 2
Error Record 3

Figure 3-6 EEPROM Information Print (Sample)

The error records record the last three user-unrecoverable errors, except for ROM/RAM errors, with the most recent being Error Record 1. Error codes in ASCII are shown below.

ERROR	Error Code (Printer Driver or Status Monitor)	In ASCII (EEPROM Data Printout)
EEPROM error	6800	36 38 30 30
Home position error	5100	35 31 30 30
Temperature sensor error	5400	35 34 30 30
Waste ink full error	5B00	35 42 30 30
Head temperature error	5200	35 32 30 30
Head temperature sensor error	5200	35 32 30 30
Cartridge displaced error	5600	35 36 30 30
Ink sensor error	...	35 39 31 30
ASF sensor error	5700	35 37 30 30

2.4 Resetting the EEPROM

The EEPROM records various settings, the data on the total number of sheets passed with the Black/Color/Photo BJ cartridges and Scanner cartridge, the total waste ink amount, and data on the last three user-unrecoverable errors. The printer detects "waste ink full" with the total waste ink amount recorded in the EEPROM. When the waste ink absorber is replaced, the data for the total waste ink amount must be reset. Also, when the control board is replaced, the EEPROM of the new control board must be reset and the waste ink absorber replaced.

2.5 Model Settings with EEPROM

The control board of this printer is used in common with other models of Canon printers. When the control board is replaced, the initial data must be set to correspond with the machine.

After setting the model, perform the service/factory test print to confirm the settings.

2.6 Ink Presence Check

The printer will scan the carriage to detect the amount of ink remaining in the ink tank, and print the result. The operation of the ink sensor can be verified with this function.

- 1) Install an empty ink tank into the BJ cartridge.
- 2) Using the Ink Presence Check function, printout the result.
- 3) Confirm that the value of "ExistInk" is "0" for the ink tank that is empty.

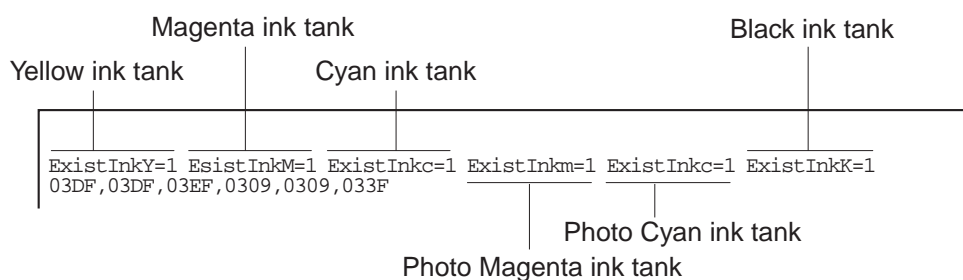

Figure 3-7 Ink Check

2.7 Power Off/Carriage Lock

The printer will move the carriage to the home position, lock the carriage, and turn itself off, regardless of the presence/absence of a BJ cartridge in the carriage.

This page intentionally left blank.



Part 4

TROUBLESHOOTING

Page	
4 - 1	1. TROUBLESHOOTING BY ERROR INDICATIONS
4 - 1	1.1 Initial Flow Chart
4 - 4	1.2 List of Errors (Indicator/error codes)
4 - 5	1.3 Troubleshooting by Error Indications
4 - 17	2. TROUBLESHOOTING BY SYMPTOMS
4 - 17	2.1 Troubleshooting by Symptoms

1. TROUBLESHOOTING BY ERROR INDICATIONS

1.1 Initial Flow Chart

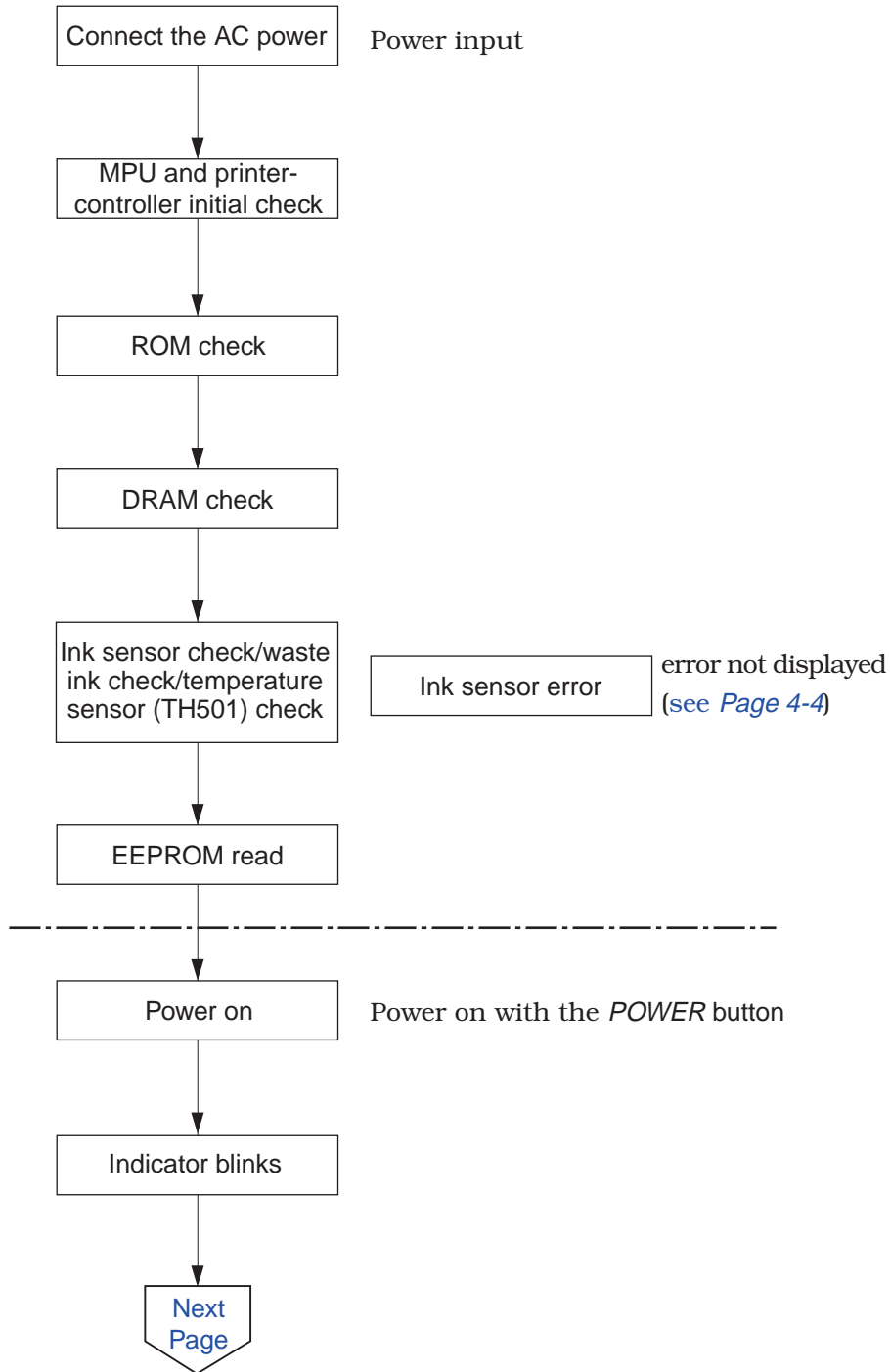

Troubleshooting

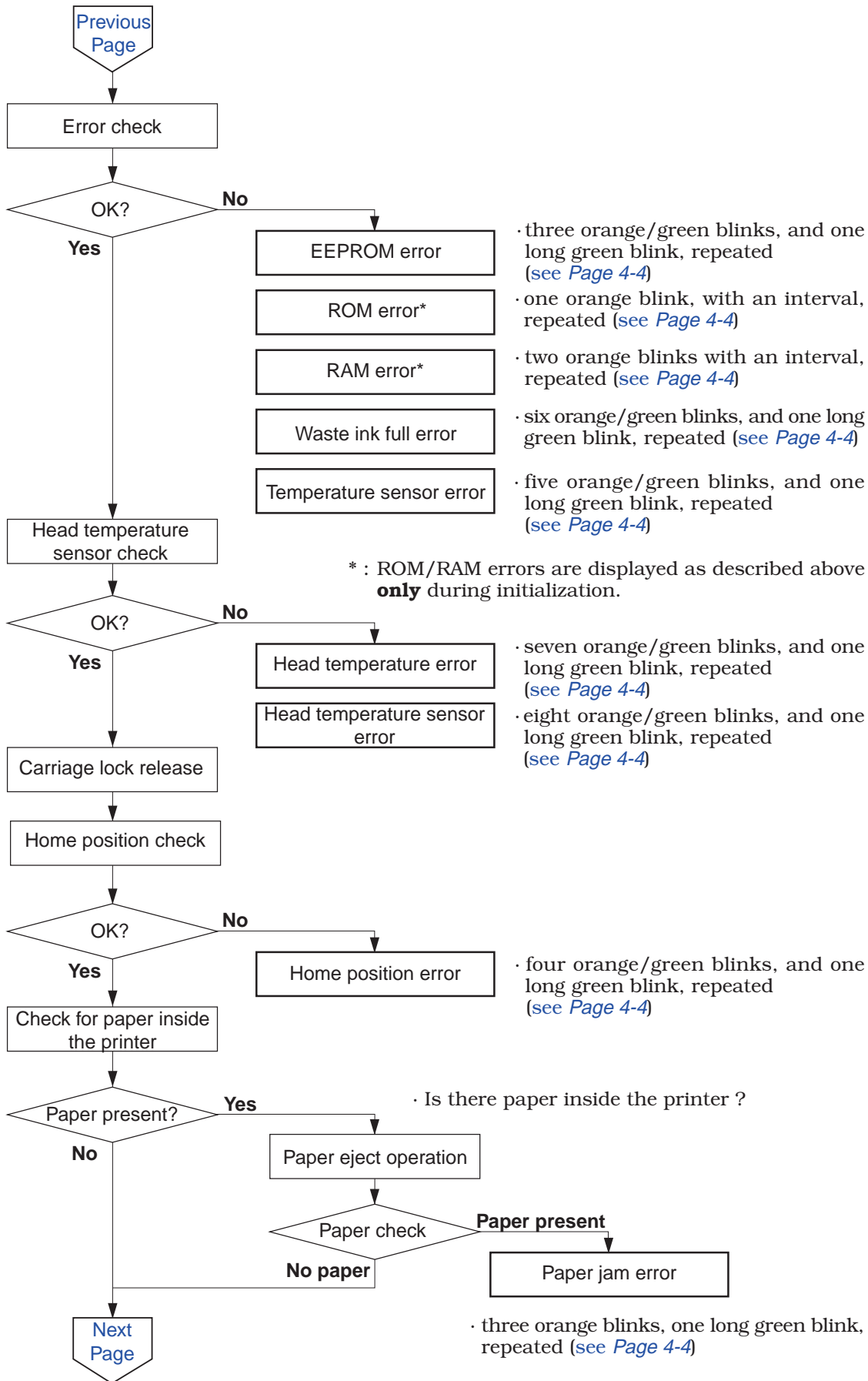

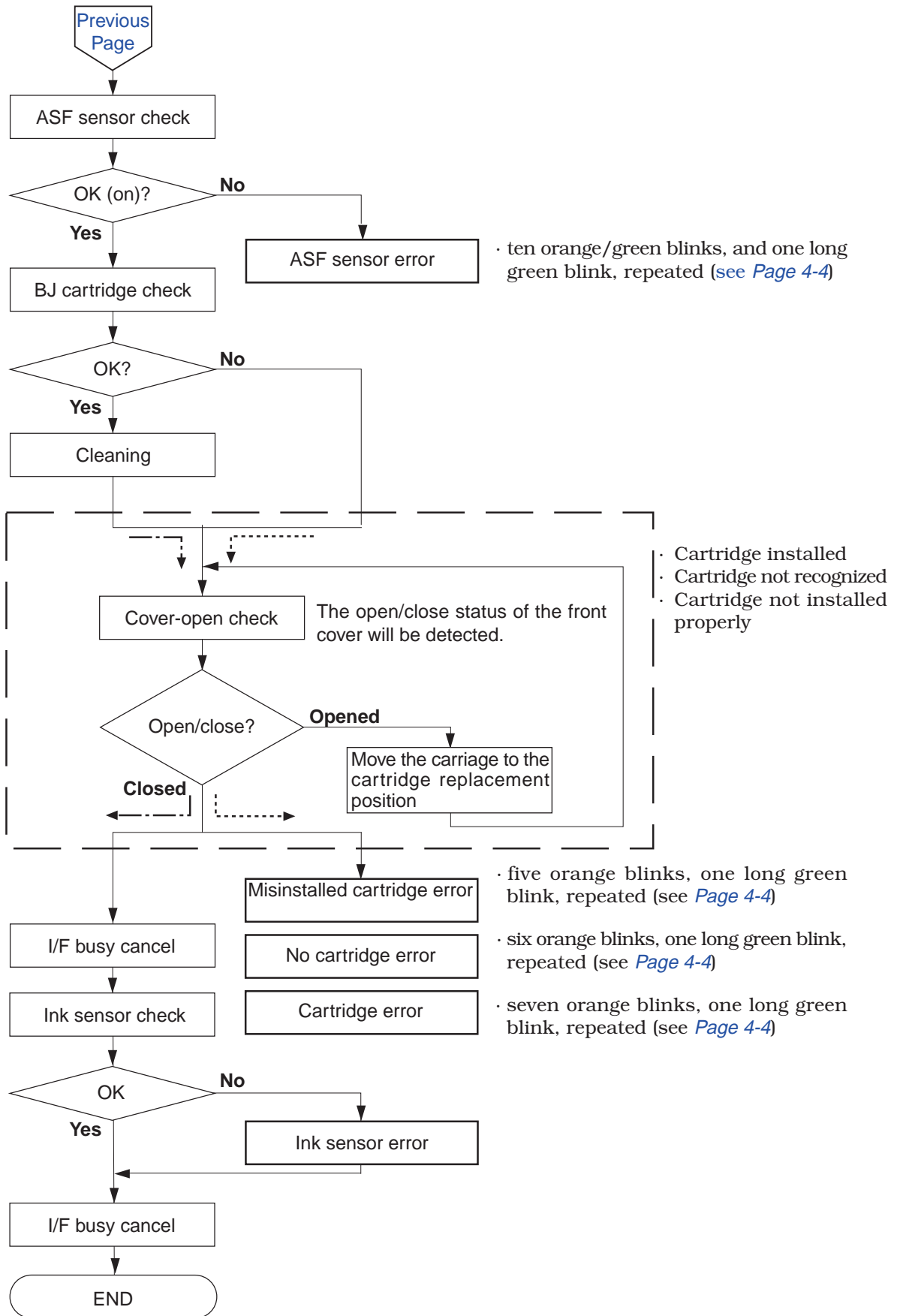

Troubleshooting

1.2 List of Errors (Indicator/error codes)

1) Recoverable by Users

The indicator blinks in orange the number of times for that type of error, then it blinks in green. This procedure is repeated.

2) Unrecoverable by Users

The indicator blinks alternately in orange and in green the number of times for that type of error (orange and green blinking alternately), then it blinks long in green. The procedure is repeated.

TABLE 4-1 ERROR DISPLAY

Error Conditions	Indicator Blinks	Error Codes*	Reference Pages
<i>[Recoverable by Users]</i>			
Paper feed error	2 times in orange	...	Page 4-12
Paper jam error	3 times in orange	...	Page 4-12
Ink out error	4 times in orange	...	Page 4-14
Misinstalled cartridge error	5 times in orange	...	Page 4-15
No cartridge error	6 times in orange	...	Page 4-15
Cartridge error	7 times in orange	...	Page 4-15
Waste ink warning**	8 times in orange	...	Page 4-5
<i>[Unrecoverable by Users]</i>			
ROM error	1 time in orange/green	...	Page 4-5
RAM error	2 times in orange/green	...	Page 4-5
EEPROM error	3 times in orange/green	6800	Page 4-5
Home position error	4 times in orange/green	5100	Page 4-6
Temperature sensor error	5 times in orange/green	5400	Page 4-5
Waste ink full error	6 times in orange/green	5B00	Page 4-5
Temperature error	7 times in orange/green	5200	Page 4-9
Head temperature sensor error	8 times in orange/green	5200	Page 4-9
Cartridge displaced error	9 times in orange/green	5600	Page 4-10
ASF sensor error	10 times in orange/green	5700	Page 4-11
<i>[Internal Error]</i>			
Ink sensor error***	None	...	Page 4-16

* : Error codes are displayed on the computer. When the printer is connected to iMac or Power Macintosh G3, "D" or "M" is prefixed to an error code.

** : Waste ink warning can be canceled by pressing the *RESUME* button.

*** : Internal errors are not displayed. Errors can be confirmed with *Part 3: 2.3 EEPROM Information Print*. (Page 3-10).

1.3 Troubleshooting by Error Indications

1. ROM Error

<Cause> Initial ROM data cannot be read
 <Suspected Parts> Control ROM
 <Measures> Replace the ROM or the control board

2. RAM Error

<Cause> RAM readout/write-on cannot be executed properly
 <Suspected Parts> DRAM, MPU and print controller
 <Measures> Replace the control board

3. EEPROM Error

<Cause> EEPROM readout cannot be executed properly
 <Suspected Parts> EEPROM, MPU and print controller
 <Measures> Replace the control board



In the event of ROM or RAM errors, errors may not be properly displayed.

4. Temperature Sensor Error

<Cause> Thermistor is abnormal
 <Suspected Parts> Thermistor
 <Measures> Replace the control board

5. Waste Ink Full Error/ Waste Ink Warning

<Cause> The waste ink absorber's estimated waste ink amount has reached 100% or 95%
 <Suspected Parts> Waste ink absorber, control board
 <Measures> 1. Reset the EEPROM and replace the waste ink absorber.
 2. Replace the control board

6. Home Position Error

<Cause> The home position cannot be detected by the home position sensor.
<Suspected Parts> Home position sensor, carriage motor, paper feed motor, control board, carriage ribbon cable, carriage board, DC cable

<Measures>

Visual check Check for paper jams, wear/deterioration/dislocation of the carriage belt, deformation of the carriage guide frame, scratching/bending of the guide shaft, etc.
 Move the carriage manually and check that it moves smoothly and there is no abnormal noise or there is no major damage on the carriage ribbon cable.

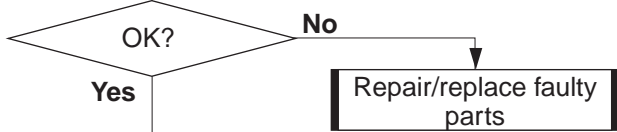

Power on with the cover opened

Visual check of the carriage unit operation Check for the proper operation of the carriage unit, and that no part is out of sync.

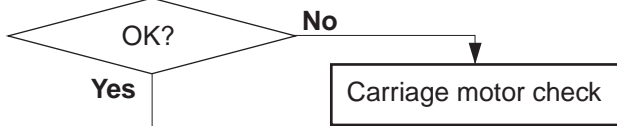

Carriage motor check

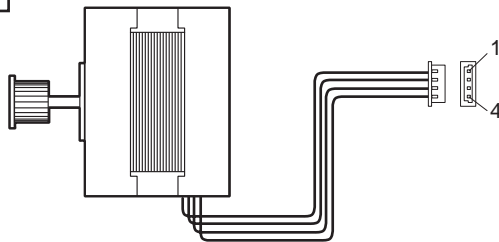

Measuring points		Normal Reading
CN402	1-3	Approx. 3.3 Ω
Pin No.	2-4	

Disconnect the carriage motor cable from the control board to check.

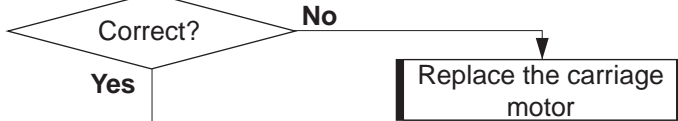

Go to Page 4-8 (1)

Next Page

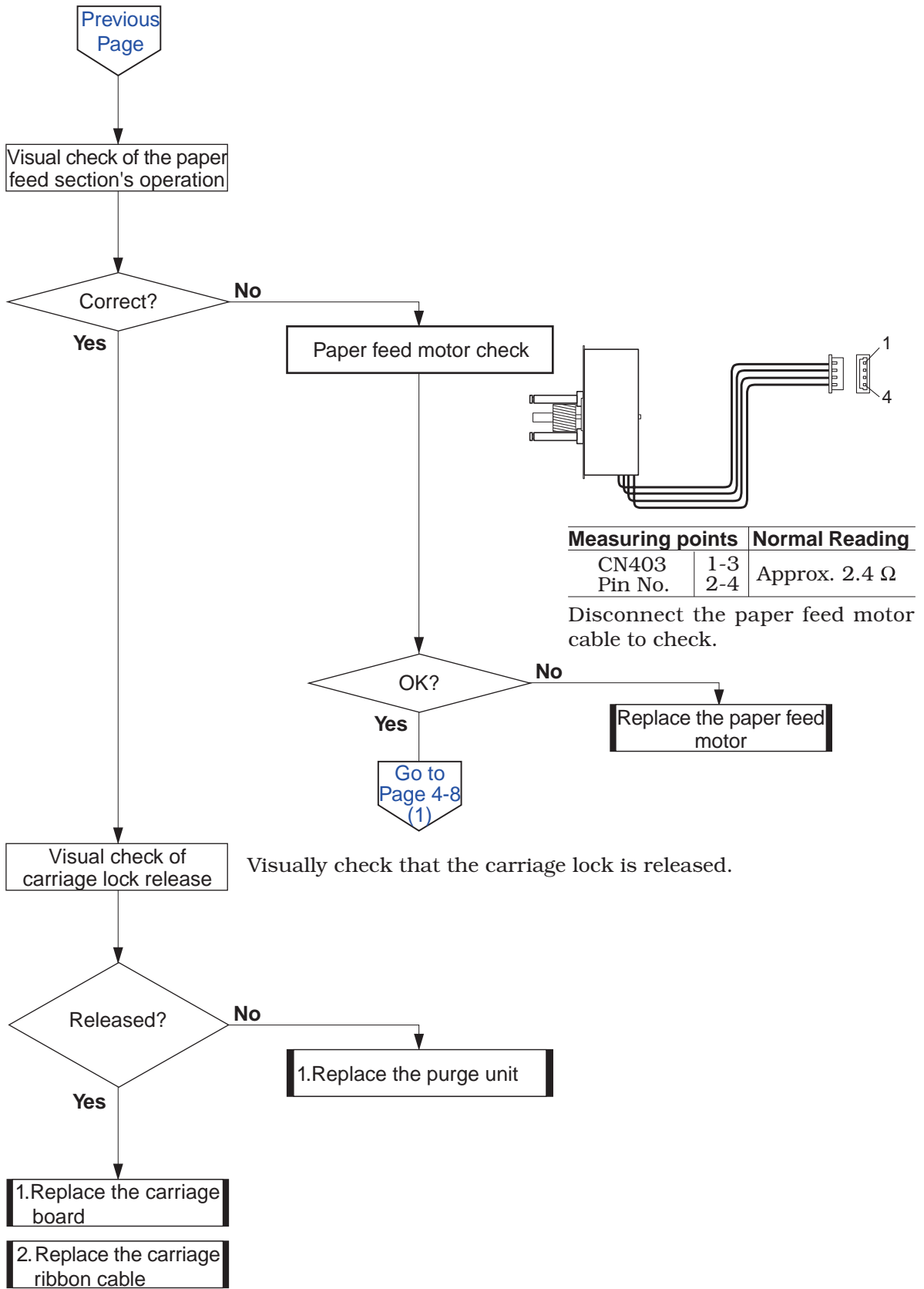

Troubleshooting

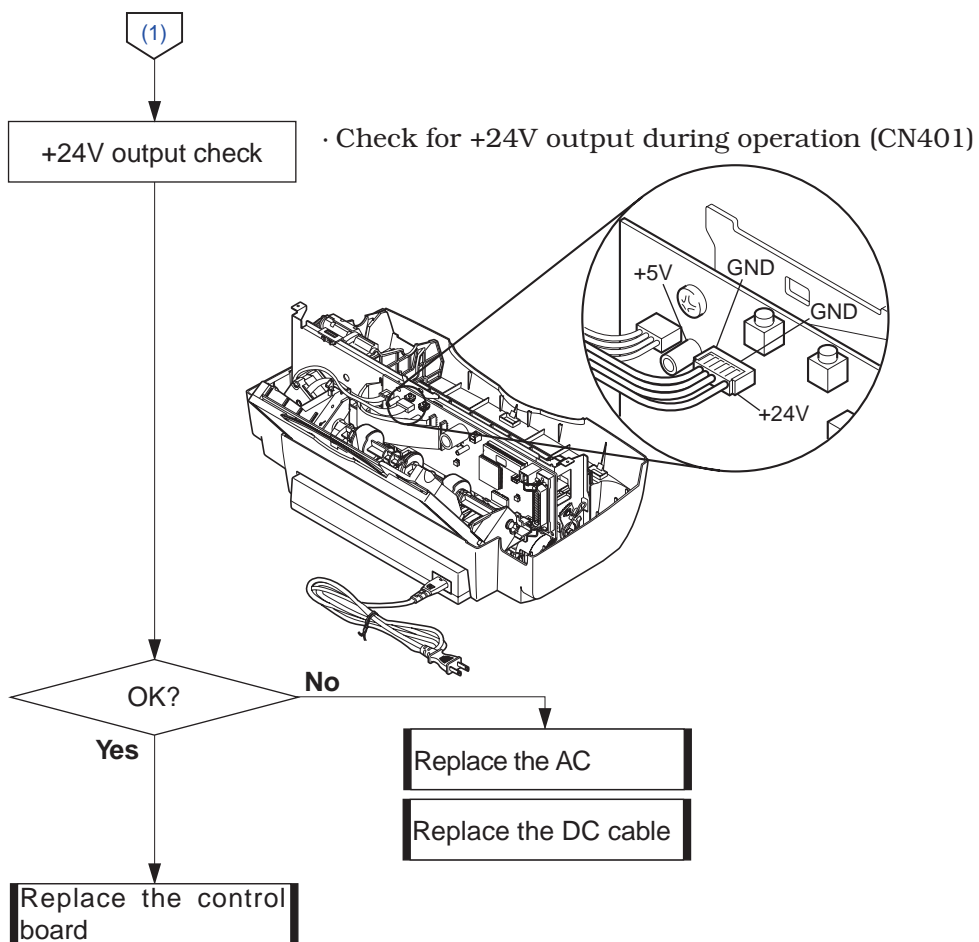

7. Head Temperature Error/ Head Temperature Sensor Error

<Cause> The head temperature is abnormally high.
The temperature on the head does not lower even after the head part is turned off.
<Suspected Parts> BJ cartridge, control board, empty ink tank.

<Measures>

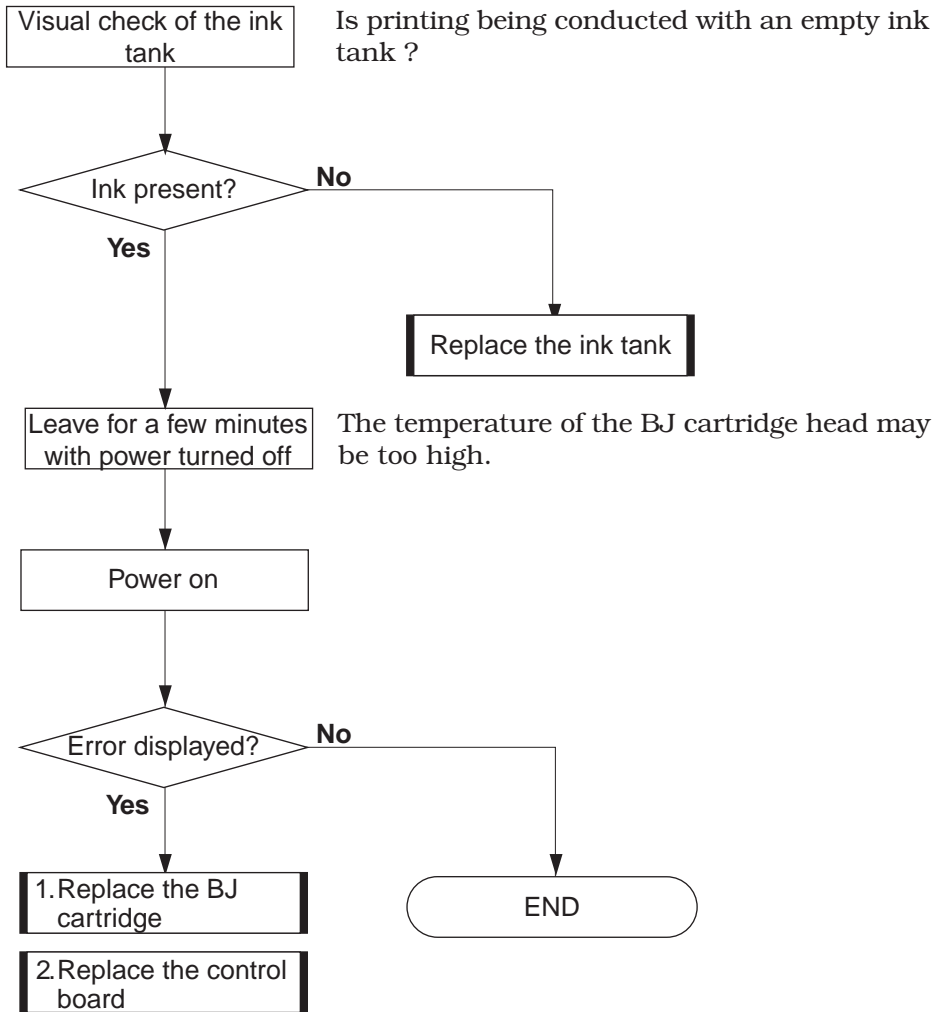

Troubleshooting

8. Cartridge Displaced Error

<Cause> The cartridge is not installed correctly outside of the cartridge replacement position.

<Suspected Parts> Cartridge, control board, carriage board, carriage ribbon cable

<Measures>

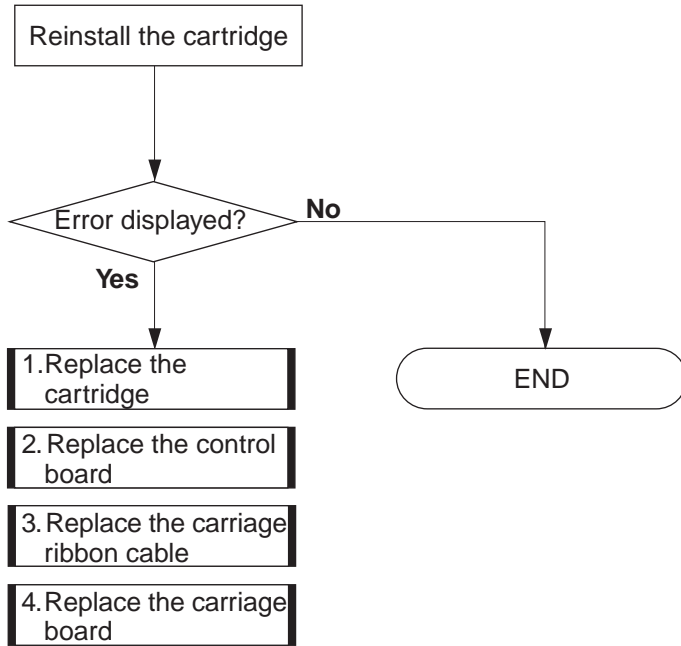

9. ASF Sensor Error

<Cause> · The pick-up roller does not rotate.
· The LF roller drive does not switch properly.
<Suspected Parts> Purge unit, control board, faulty ASF gear adjustment

<Measures>

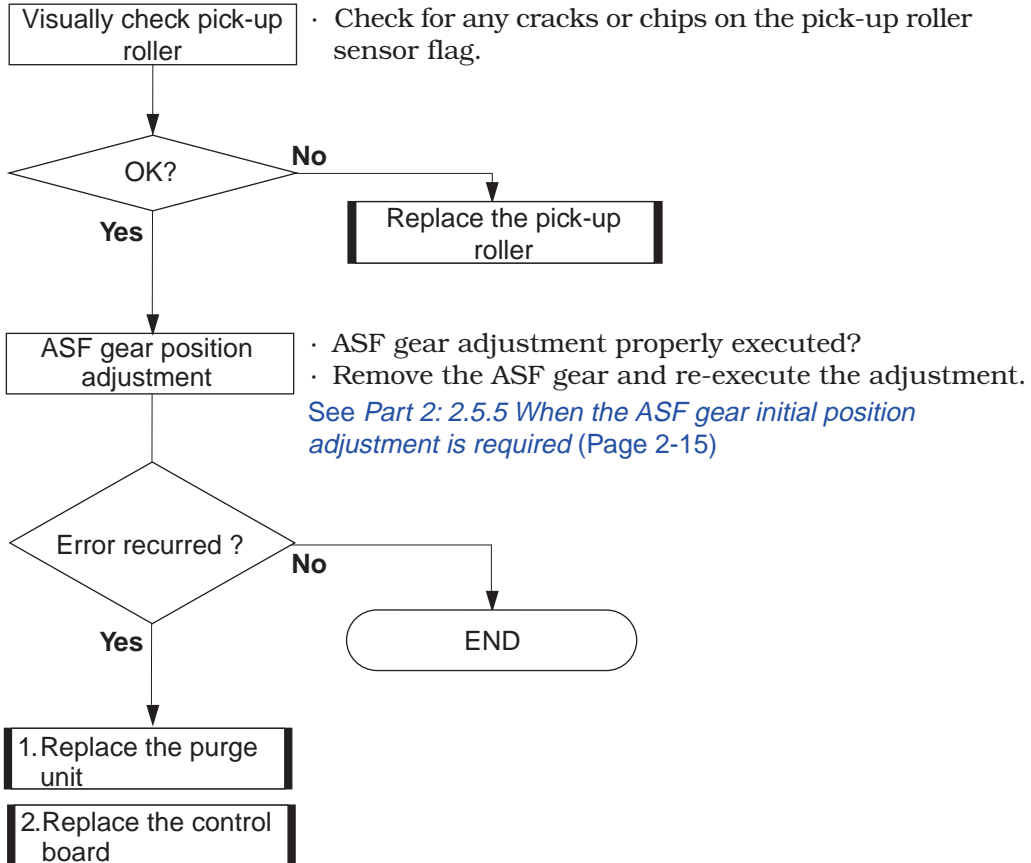

Troubleshooting

10. Paper Feed Error/ Paper Jam

<Cause> · The paper-feed operation is executed but the paper is not fed.
· The paper-eject operation is executed but the paper is not ejected.

<Suspected Parts> Paper feed parts, paper end sensor, control board

<Measures>

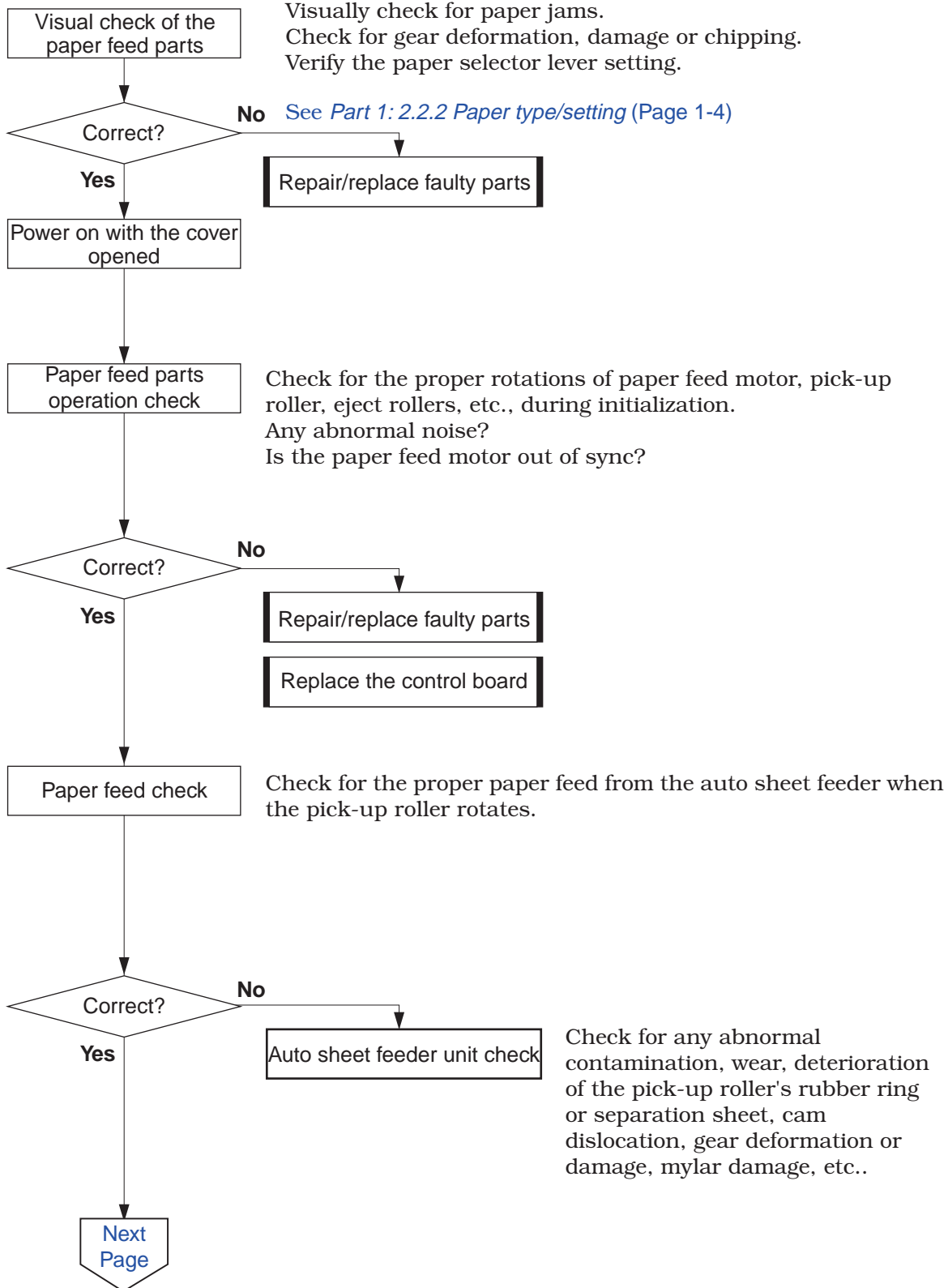

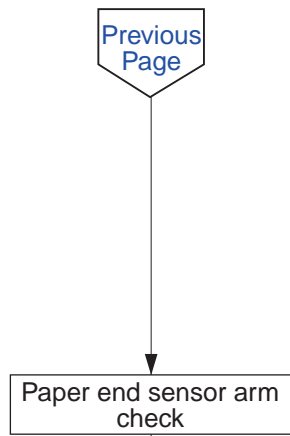
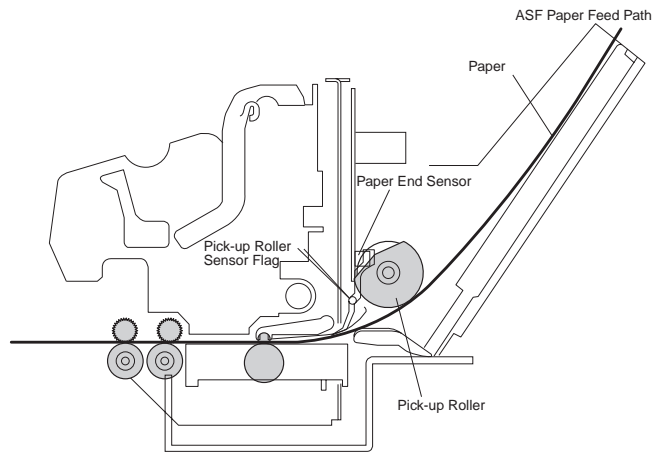

Check with paper to verify that it moves smoothly. Check for deformation or damage.

Replace paper end sensor arm

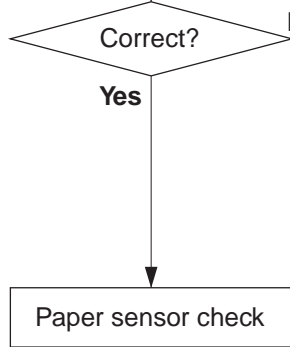

Measuring points	Sensor	Normal Reading
IC201	Opened	Low level (with paper)
Pin No.203	Closed	High level (without paper)

Check the paper end sensor arm with paper while the power is turned on.

Replace the control board

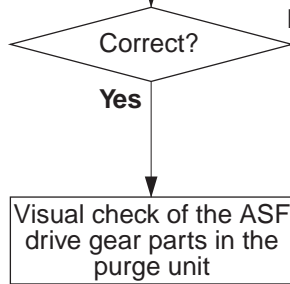

Check for any gear dislocation, missing cogs, parts damage and deformation.

Replace the purge unit

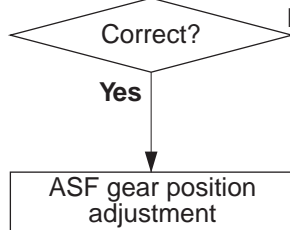

See Part 2: 2.5.5 When the ASF gear initial position adjustment is required (Page 2-15).

Troubleshooting

11. Ink Out Error

<Cause> · Empty ink tank
· Faulty EEPROM

<Suspected Parts> Ink tank, EEPROM

<Measures>

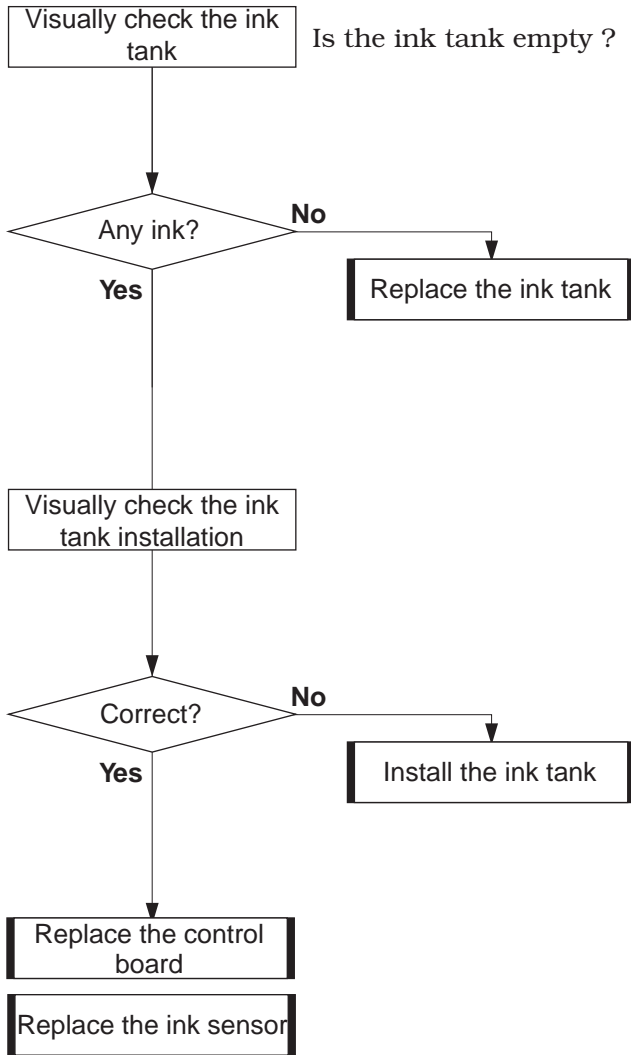

12. Cartridge Error/ Misinstalled Cartridge Error/ No Cartridge Error

<Cause> · Cartridge is not recognized.
· Cartridge is not installed.

<Suspected Parts> Cartridge, carriage board, control board,
carriage ribbon cable, faulty contacts between
the cartridge and the cartridge interface.

<Measures>

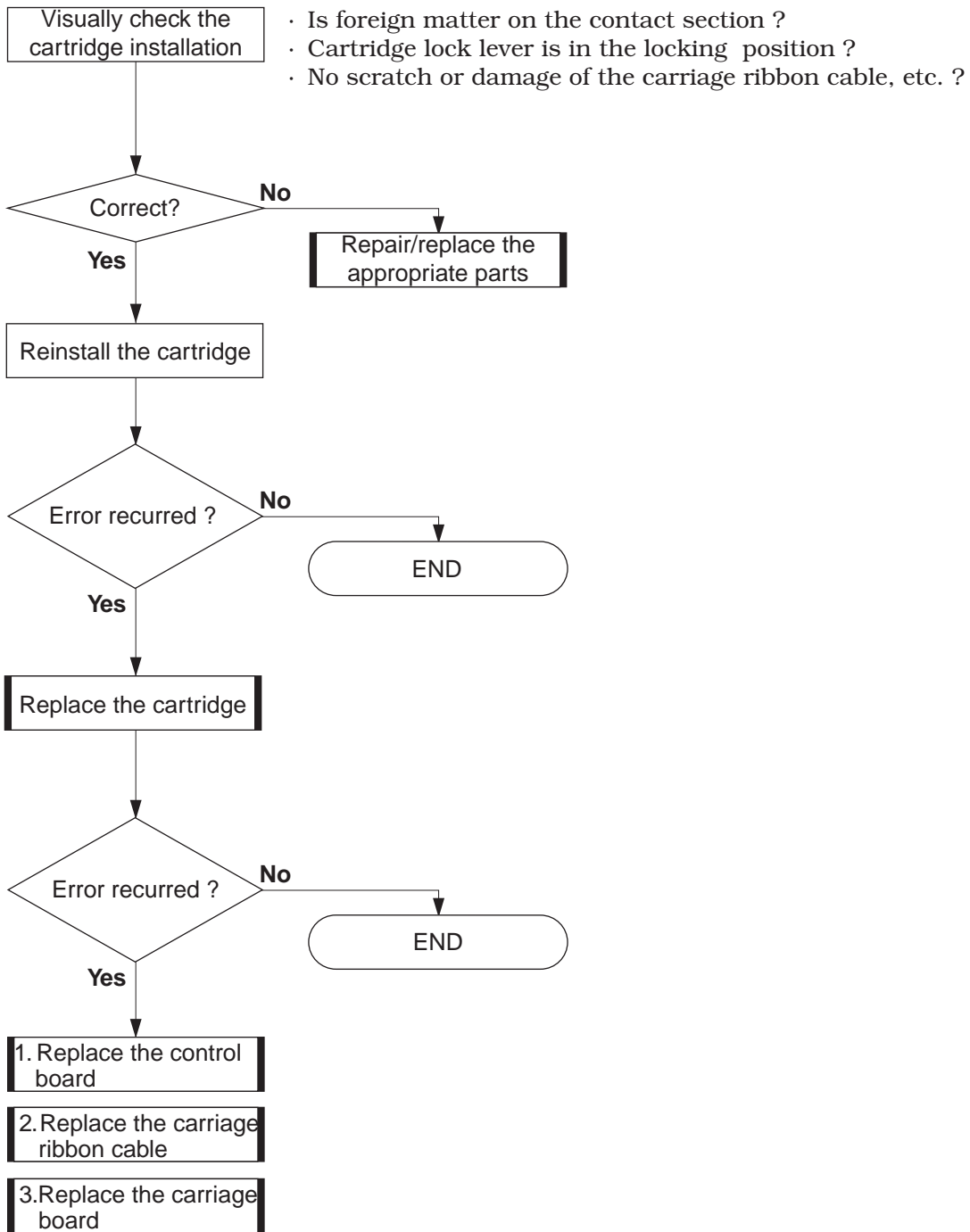

Troubleshooting

13. Ink Sensor Error*

<Cause> Ink is detected to be present even when there is none.
<Suspected Parts> Ink sensor, control board, ink tank.

* : Treated as an internal error; error information is not displayed.
 Can be checked with the EEPROM information print.

<Measures>

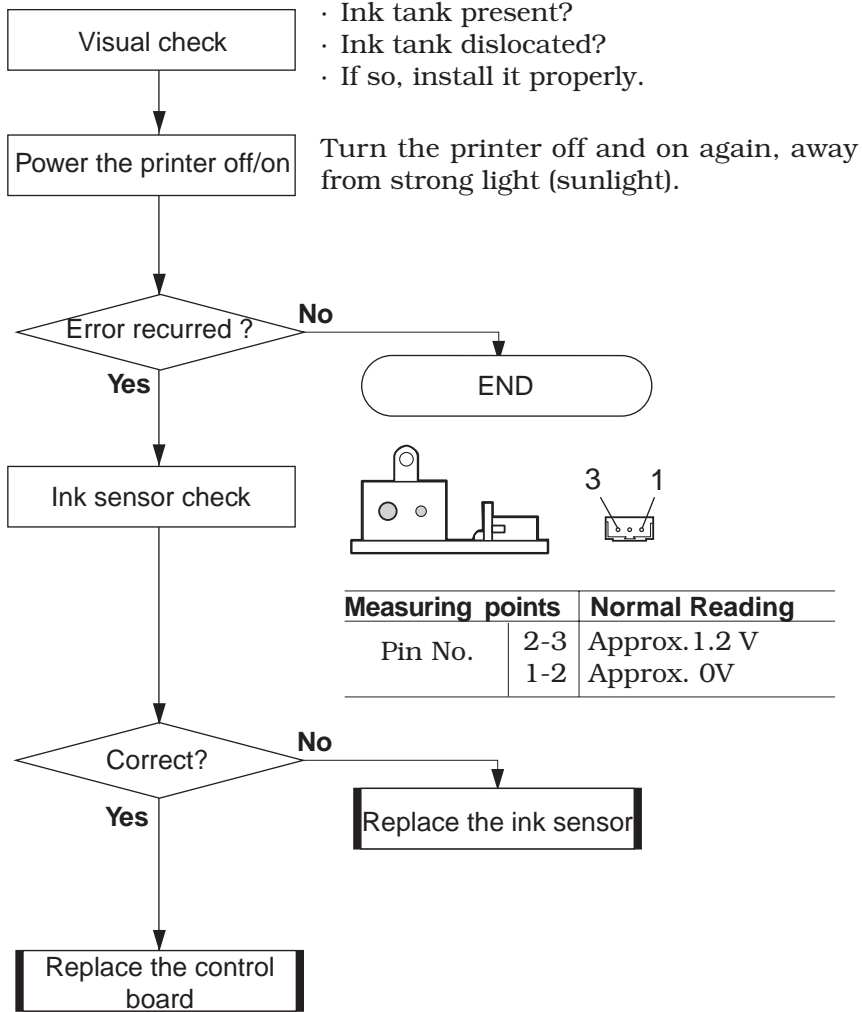

2. TROUBLESHOOTING BY SYMPTOMS

2.1 Troubleshooting by Symptoms

1. The Power Does Not Turn On

<Symptom> · The printer does not turn on even when the *POWER* button is pressed.

· The printer does not perform initialization even when the *POWER* button is pressed.

<Cause> Faulty AC adapter, control board, or DC cable.

<Measures>

Check the AC adapter output voltage (+5V/24V)

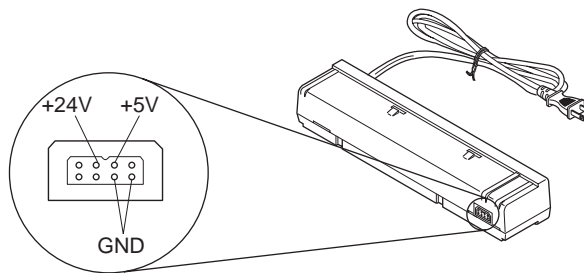

Correct?

No

Yes

Replace the AC adapter

Replace the control board

Replace the DC cable

Troubleshooting

2. Faulty Printing/ No Printing

- <Symptom>** · The printer does not print at all.
 · Printing stops midway.
 · Certain colors are not printed.
- <Cause>** · Faulty ink tank, BJ cartridge, or purge unit.
 · Orange cap/tape is on the head.

<Measures>

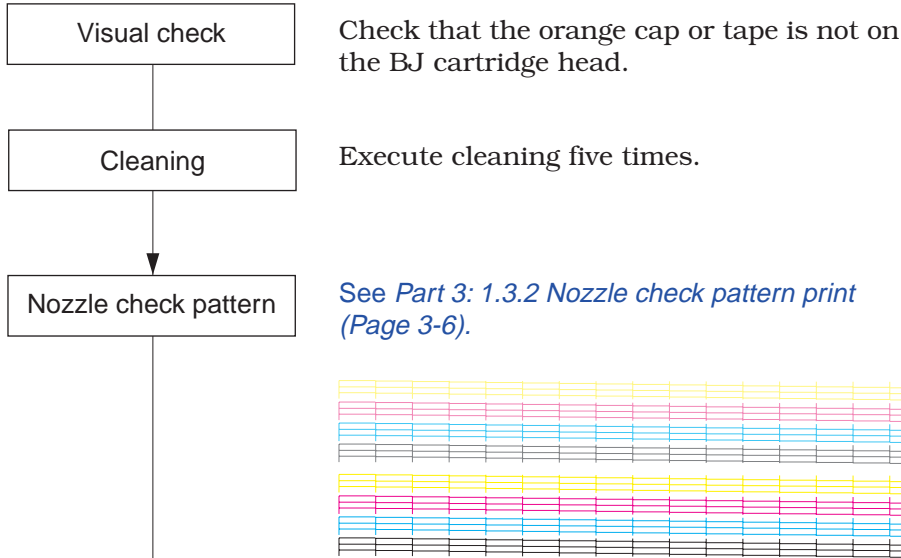

Nozzle check pattern See Part 3: 1.3.2 Nozzle check pattern print (Page 3-6).

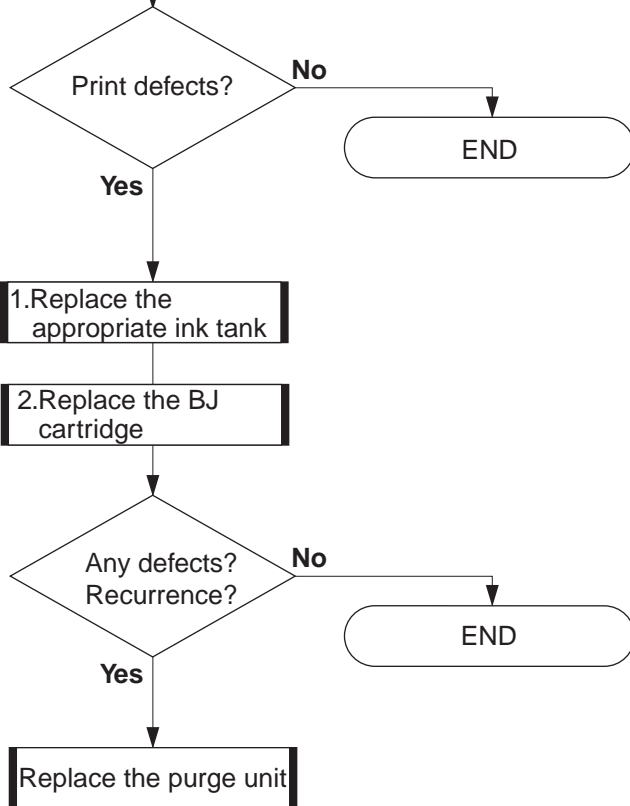
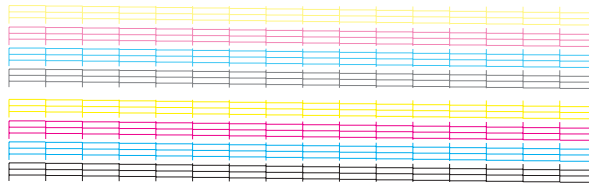

3. Faulty Printing /Blank Lines Appear

<Symptom> · Blotches appear
· Blank lines appear
· Specified dots are not printed

<Cause> BJ cartridge, faulty BJ cartridge contacts, carriage ribbon cable, purge unit, control board, carriage board, faulty ink tank.

<Measures>

Cleaning

Execute cleaning five times.

Nozzle check pattern

See Part 3: 1.3.2 Nozzle check pattern print (Page 3-6).

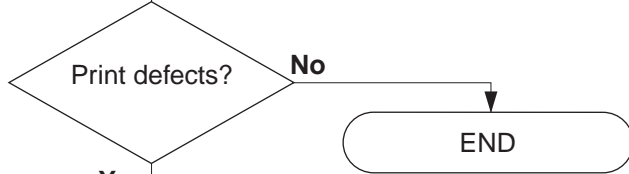
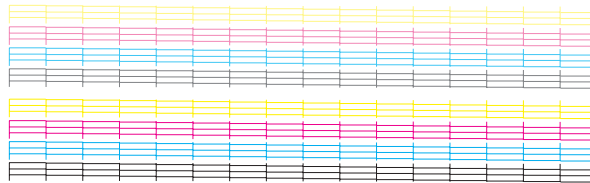

Yes

1. Replace the appropriate ink tank

2. Replace the BJ cartridge

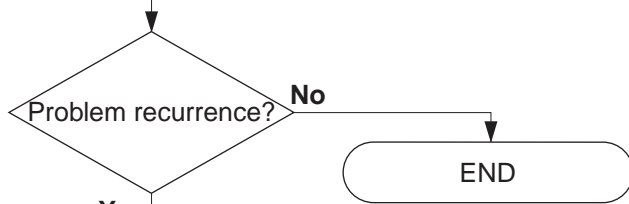

Yes

Next Page

Troubleshooting

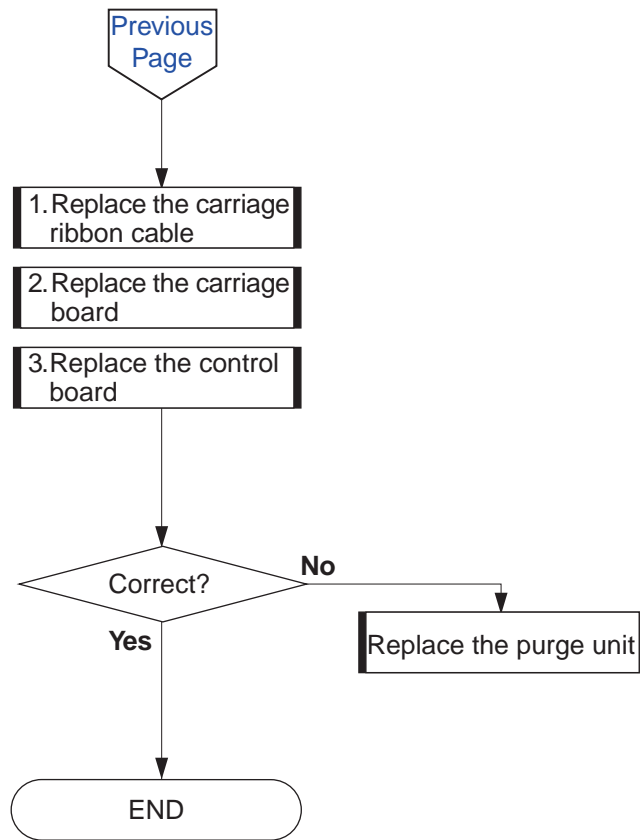

4. Faulty Printing /Other Printing Problems

Symptom	Check Item	Measures
• Paper contamination	Ink mist, etc., on the paper guide plate on the platen.	Clean with a soft moist cloth.
	Ink has adhered to the paper feed section. (The paper is already contaminated by the time it reaches the platen.)	Disassemble and clean the paper feed section with a soft moist cloth. Pass a few sheets.
• Spur marks appear	The spur tips are deformed.	Replace the spur unit.
• Vertically-oriented lines are mis-aligned	The paper selector lever is not set in the appropriate position.	Set the lever to the specified position.
	Check for misalignment in the nozzle check pattern print.	Readjust the print position.
	Grease application on the guide shaft.	Apply the appropriate amount in the specified place.
	Carriage motor status	Replace the carriage motor.

5. No Error Indication When There Is No Ink

<Symptom> Error is not displayed even when the ink is empty.
<Cause> No ink, faulty control board or ink sensor

<Measures>

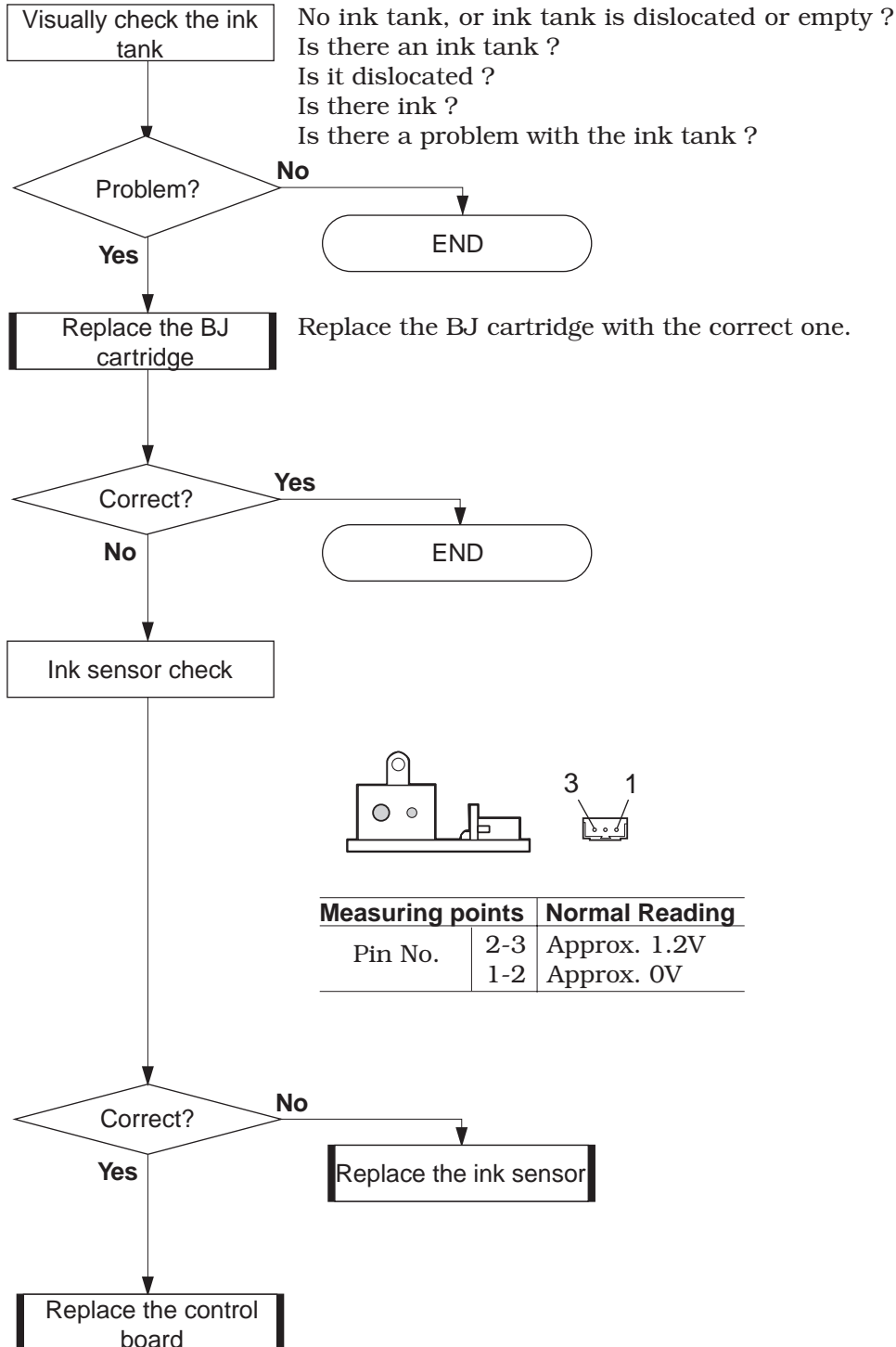



Part 5

APPENDIX

Page	
5 - 1	1. TECHNICAL REFERENCE
5 - 1	1.1 About the Paper Feed Section
5 - 4	1.2 About the Purge Unit
5 - 7	1.3 About the Electrical Section
5 - 10	1.4 About the BJ Cartridge
5 - 12	1.5 About the Scanner Cartridge
5 - 15	2. CONNECTORS AND PIN LAYOUT
5 - 15	2.1 Control Board
5 - 19	2.2 Carriage Board
5 - 20	2.3 BJ Cartridge
5 - 21	2.4 Scanner Cartridge (Optional)
5 - 22	2.5 AC Adapter
5 - 22	2.6 DC Power Supply Cable
5 - 23	2.7 Carriage Motor
5 - 23	2.8 Paper Feed Motor
5 - 23	2.9 Ink Sensor

1. TECHNICAL REFERENCE

1.1 About the Paper Feed Section

1.1.1 Paper feed functions

In this printer, sheets are supplied automatically from the auto sheet feeder. The auto sheet feeder is driven by the paper feed motor, and paper stacked in the sheet feeder is picked up and fed automatically. Even envelopes can be fed automatically without requiring that the paper type be selected with a mechanical paper selection lever, etc.

When the paper is sensed by the photo interrupter type paper end sensor, it is fed automatically by the paper feed roller until it reaches the print start position on the platen.

During printing, the paper is fed by the rotation of the paper feed roller.

After printing, the paper is delivered by the eject roller.

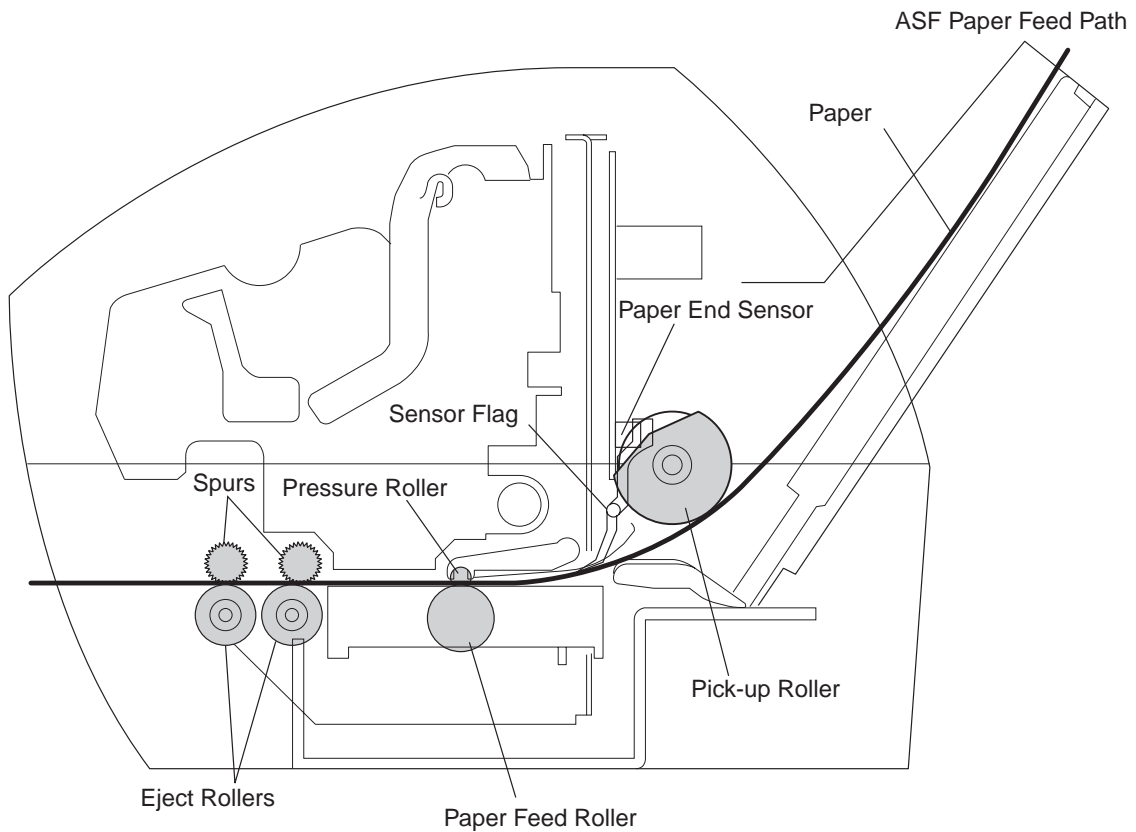

Appendix

Figure 5-1 Paper Feed Path

1.1.2 Structure of the paper feed components

The paper feed of this printer can be divided into the paper pick-up section, paper feed section, and paper delivery section, structurally.

a) Paper pick-up section

If the paper meets specifications, it can be fed without selecting the paper type mechanically. This printer therefore has no mechanical paper selection lever on the auto sheet feeder.

When paper is stacked, the slanted ASF holds the paper to avoid misfeeding caused by paper bending.

When printing starts, through the drive of the paper feed motor, the pick-up roller starts to rotate. The paper is loaded in the sheet feeder such that one corner of it is suppressed by the paper separator. When the pick-up roller rotates further, the paper, with one corner held by the paper separator, is separated and fed to the paper feed roller.

When printing on resilient paper like envelopes, as the paper is stiffer than the return force of the paper separator's spring, the paper separator is pressed down to feed the paper.

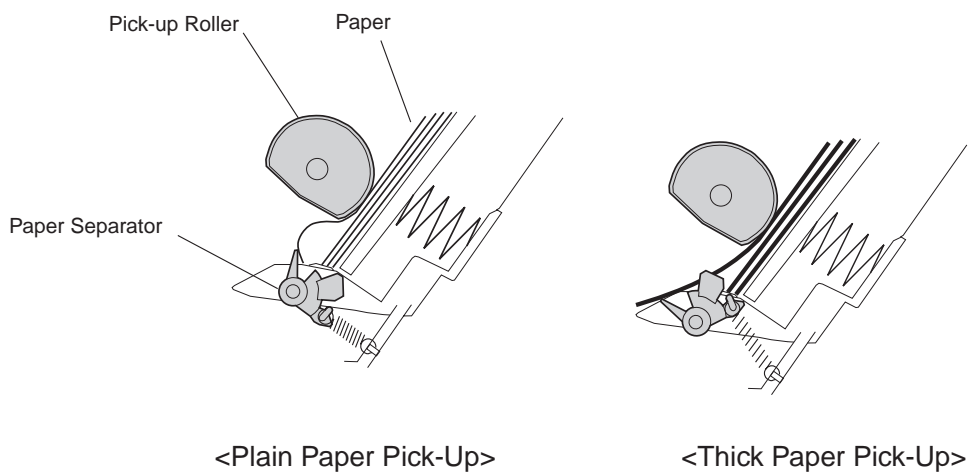

Figure 5-2 Paper Pick-Up Mechanism

b) Paper feed section

Paper feeding during printing is controlled by the rotation of the paper feed roller. Paper is fed in increments of 1/720 inch.

Between the pressure roller/paper feed roller and the spurs/eject roller, as the paper is pressed onto the platen, the head to paper distance is stabilized. After the cut sheets reach the print start position, they will be printed on over the platen.

c) Paper delivery section

This part is composed of the eject roller and spurs.

To prevent contaminating the paper's printed surface, the sharp tips of the spurs press down on the printed side of the paper, onto the eject roller, and with the drive of the eject roller, paper delivery is performed.

1.1.3 Advanced paper feed function

To improve the paper feed speed, this printer has an advanced paper feed function. With this function, when multiple pages of plain paper with a page length longer than letter-sized paper, are printed in HS mode, the printer begins feeding of the next page before ejection is completed.

1.1.4 Paper feed retry function

To improve the paper feed capability, this printer has a paper-feed retry function. When paper feeding is detected to be improper (refer to items (a) and (b) described below), the printer will reattempt paper feeding with this function. If proper paper feed cannot be realized after retrying once, the paper feed error will result. This function is performed when (a) or (b) is fulfilled:

- (a) If no paper is sensed by the paper end sensor, paper pick-up operations will be re-executed.
- (b) When the pick-up roller sensor cannot detect the pick-up roller flag, even after rotating the pick-up roller of the ASF with a set number of pulses, if the paper has reached the paper end sensor, it will be ejected, and the paper pick-up operation repeated.

1.1.5 The print start position adjustment retry function

To improve the accuracy of the print start position, this printer has a print start position adjustment retry function.

The printer uses this function when printing in HS mode.

When paper is not detected to be properly delivered to the print start position correctly (refer to item (a) described below), this function will move the paper automatically to the correct print start position.

- (a) When the paper end sensor does not detect the paper until the pick-up roller has been rotated more than the prescribed number of pulses, the printer will determine that the paper is not at the correct print start position. In this case, the rotation of the paper feed roller is reversed to perform the form alignment function, and the paper will be moved to the correct print start position.

1.1.6 The form alignment function

To improve the paper feeding capability such as reducing skew, this printer has a form alignment function. The printer uses this function when printing, except when printing in HS mode. However, if the print start position adjustment retry function has been performed, this function can be used in HS mode.

The paper is pressed to the paper feed roller and the pressure roller, which are turning in reverse to create a bend in the paper. With this bend, the paper will be fed in a straight path, even if it was set askew.

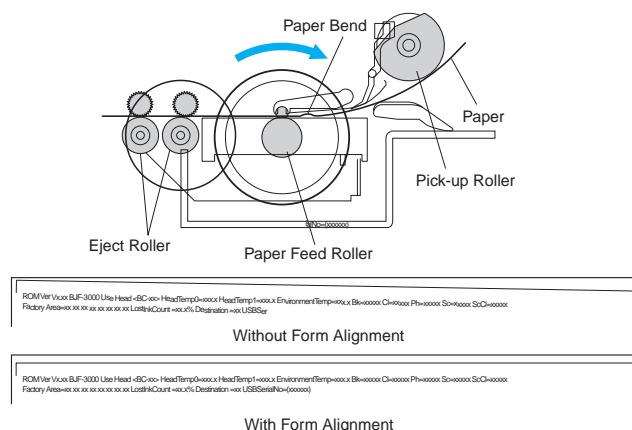

Figure 5-3 Form Alignment Function

1.2 About the Purge Unit

The purge unit maintains the nozzles of the BJ cartridge in order to maintain printing quality.

The purge unit's functions can be divided into capping, cleaning, and paper feed motor drive switching functions.

1.2.1 The capping and cleaning functions of the purge unit

The purge unit's cap is pressed against the face of the print head to prevent the ink from drying out and to avoid particles adhering to it.

Capping is performed in the following situations:

- When power is turned off with the *POWER* button.
- When the printer is at standby, uncapped, and print data is not received for a certain period of time:
 During paper-feed: after 20 minutes
 Other than during paper-feed: after 30 seconds
- After the front cover is opened for 10 minutes.

The cleaning function includes the following operations:

- suction operations: the suction of ink from the print head to refresh the nozzles with fresh ink.
- maintenance jet operations: to remove bubbles within, and dust around the nozzles, ink is ejected onto the cap and into the maintenance jet receiving section.
- wiping operations: paper fibers and ink residue is wiped from the print head's face.

Cleaning operations are performed in the following situations so that the head maintains high-quality printing.

TABLE 5-1 INK CONSUMPTION AMOUNT DURING CLEANING (REFERENCE)

With a Black BJ Cartridge	Approx. Ink Consumption
When powered on the first time after AC power is connected (capped)	Approx. 0.16g
When powered on the first time after AC power is connected (uncapped)	Approx. 0.32g
When the dot count exceeds the specified amount	Approx. 0.16g
When the power is turned on after more than 72 hours since the last cleaning	Approx. 0.16g
When cleaning is executed by button operation	Approx. 0.16g
At BJ cartridge replacement	Approx. 0.32g
At ink tank replacement	Approx. 0.32g
When cleaning is executed by the printer driver	Approx. 0.16g
When head-refreshing is executed by the printer driver	Approx. 0.32g
When the printer is unpacked (initial power on)	Approx. 0.48g
Before printing on banner paper (when the dot count or time exceeds the specified amount since the last cleaning)	Approx. 0.16g
With a Color/Photo BJ Cartridge	Approx. Ink Consumption
When powered on the first time after AC power is connected (capped)	Approx. 0.46g
When powered on the first time after AC power is connected (uncapped)	Approx. 0.84g
When the dot count exceeds the specified amount	Approx. 0.46g
When the power is turned on after more than 72 hours since the last cleaning	Approx. 0.46g
When cleaning is executed by button operation	Approx. 0.46g
At BJ cartridge replacement	Approx. 0.84g
At ink tank replacement	Approx. 0.84g
When cleaning is executed by the printer driver	Approx. 0.46g
When head-refreshing is executed by the printer driver	Approx. 0.84g
When the printer is unpacked (initial power on)	Approx. 1.22g
Before printing on banner paper (when the dot count or time exceeds the specified amount since the last cleaning)	Approx. 0.46g

1.2.2 Purge unit paper feed motor drive switching function

The paper feed motor drive switching function performs the switching of the paper feed motor's drive power to drive the auto sheet feeder or the purge unit.

1.2.3 Purge unit structure and functions

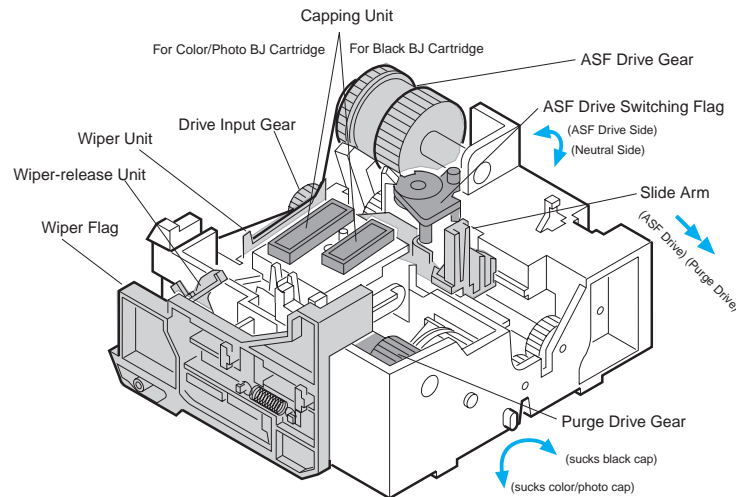

Figure 5-4 Purge Unit Structure

a) Paper feed motor drive switching unit

The paper feed motor drive switching unit uses the slide arm, which is moved and controlled by the positioning of the carriage, to perform the switching of drive power from the drive input gear to drive the auto sheet feeder (ASF) or the purge unit. For auto sheet feeder drive, the slide arm moves to the right, moving the ASF drive switching flag into the ASF drive position where, with rotation of the paper feed section in the reverse direction, paper pick up operations commence. The slide arm will then move the ASF drive switching flag into the neutral position, and the rotation of the ASF drive gear stops automatically as the pick-up motion is completed.

For purge unit operation, the slide arm is moved further right than during auto sheet feeder operation. Operations described below will be executed according to the direction in which the paper feed roller rotates:

- Direction of paper feed: the purge drive gear rotates counterclockwise for suction on the Color/Photo BJ cartridge cap side.
- Reverse direction of paper feed: the purge drive gear rotates clockwise for suction on the Black BJ cartridge cap side.

b) Capping unit

Two caps are provided for use according to the type of BJ cartridge installed in the carriage. Facing the purge unit, the left cap is for the Color/Photo BJ cartridges and the right cap is for the Black BJ cartridge.

The capping unit is connected to a pump unit in the purge unit. The capping unit uses the pump unit to suck ink from the head during cleaning operations. One pump unit is responsible for ink suction for both types of cartridges, separately. When the Color/Photo BJ cartridge is being used, the purge drive gear will rotate counterclockwise as shown in *Figure 5-4*; when the Black BJ cartridge is used, it rotates in the reverse direction.

The ink which has been sucked out is sent to the waste ink absorber through the pump unit. After suction is completed, the carriage is moved to a position where a small gap between the cap and the head is created, and pumping operations to suck the waste ink from within the cap are conducted.

c) Wiper unit

The wiper unit, controlled by the position of the carriage unit, performs wiping operations.

When the carriage moves from left to right, the carriage moves the purge unit's wiper flag, and while raising and setting the wiper, caps the cartridge.

When the carriage moves from right to left, the wiper wipes, after which the carriage moves the wiper release unit to unlock the wiper latch and the wiper is lowered.

1.3 About the Electrical Section

1.3.1 Electrical section block diagram

Block diagrams of the control board and the carriage board are shown below.

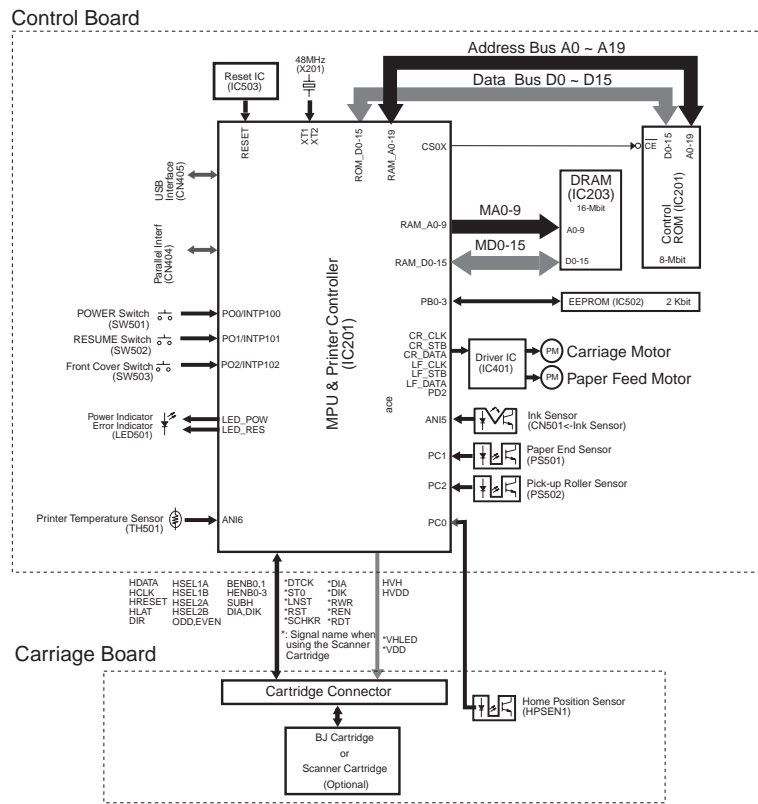

Figure 5-5 Block Diagram

1.3.2 Power line block diagram

This printer's power voltage is 5V/24V/3.3V. The power line block diagram is shown below.

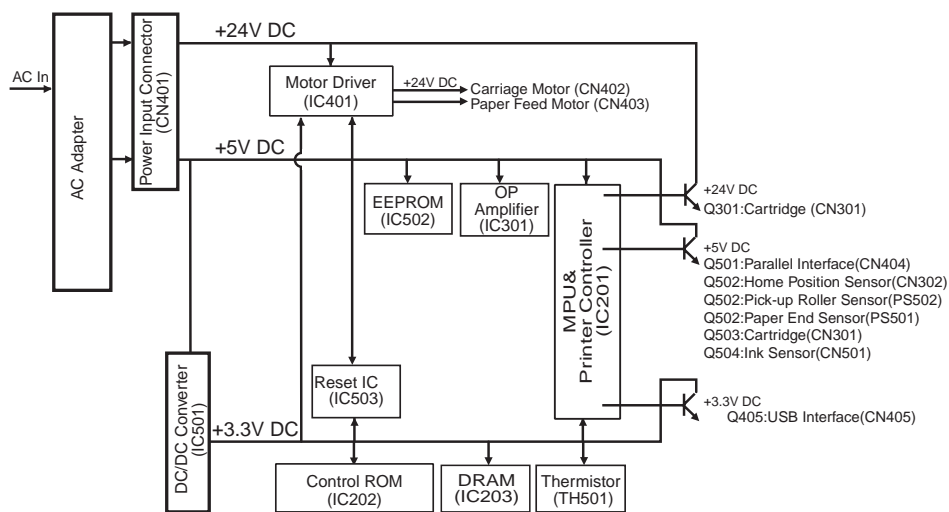

Figure 5-6 Power Line Block Diagram

1.3.3 USB interface

USB is a serial interface which connects up to 127 peripheral devices to a host computer, and transmits data at a high-speed rate of 12Mbps. Hot plugging, in which connecting/disconnecting devices while the host or the printer is in use, is supported. Each device is connected to a hub's port, where each port's detection/disconnection status is returned to the host.

Data transfer

The data transfer in USB is executed in terms of the transfer unit called a frame, a time frame of approximately 1ms, into which the data is divided. Data is transferred by piling up these frames.

All packets begin with a SYNC (synchronizing) field to synchronize with the local clock, and are separated with an EOP (End of Packet) field.

Frame lines begin with an SOF (Start of Frame) packet. An SOF is composed of a PID (Packet Identification Field) that represents the type of the packet and the direction, frame number, and a CRC (Cyclic Redundancy Check) used for error-check.

Inside a frame is a packet line containing a token packet, data packet and a handshake packet, which indicates the status of the flow control.

A token packet is composed of a PID, an address field which can specify up to 128 addresses, an ENDP (endpoint) field, and a CRC.

Inside a data packet are a PID, data field, CRC, and EOP.

Only a PID is present inside the handshake packet.

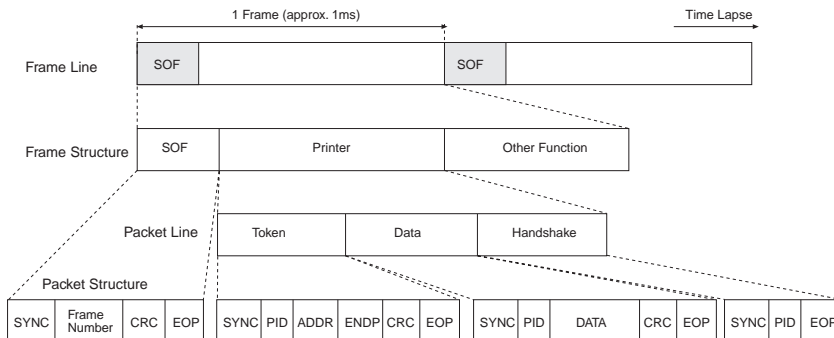

Figure 5-7 USB Data Transfer

Encoding/Decoding the Data

In USB, data transfer lines are ultimately encoded with NRZI (Non Return to Zero Invert) method. When the original data bit is 0, sent data bits are inverted; when the original data bit is 1, the value is retained.

However, if the level of the transferred data remain unchanged for a certain period of time, the receiving side may not be able to synchronize with the data sample position, which will result in data bits being out of phase. This is prevented by a method called bit stuffing; when data bit 1 is repeated 6 times, one 0 bit is added to the original data before encoded with NRZI.

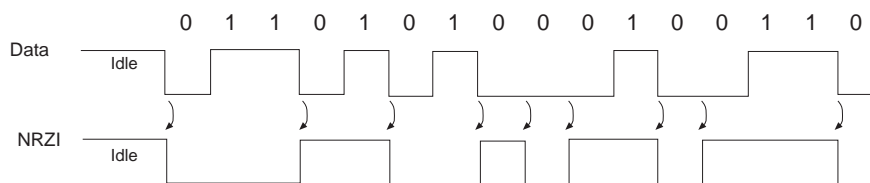

Figure 5-8 NRZI

1.3.4 Automatic interface switching function

This printer has a function to automatically switch the interface.

With this function, when printing is not executed from either interface, printing can be executed from either the USB or the parallel interface.

The switching cannot be performed until after the printing starts from one of the interfaces and the buffer becomes empty after printing.

1.3.5 Detection functions with sensors

The printer detects the status of the machine with sensors, as shown below.

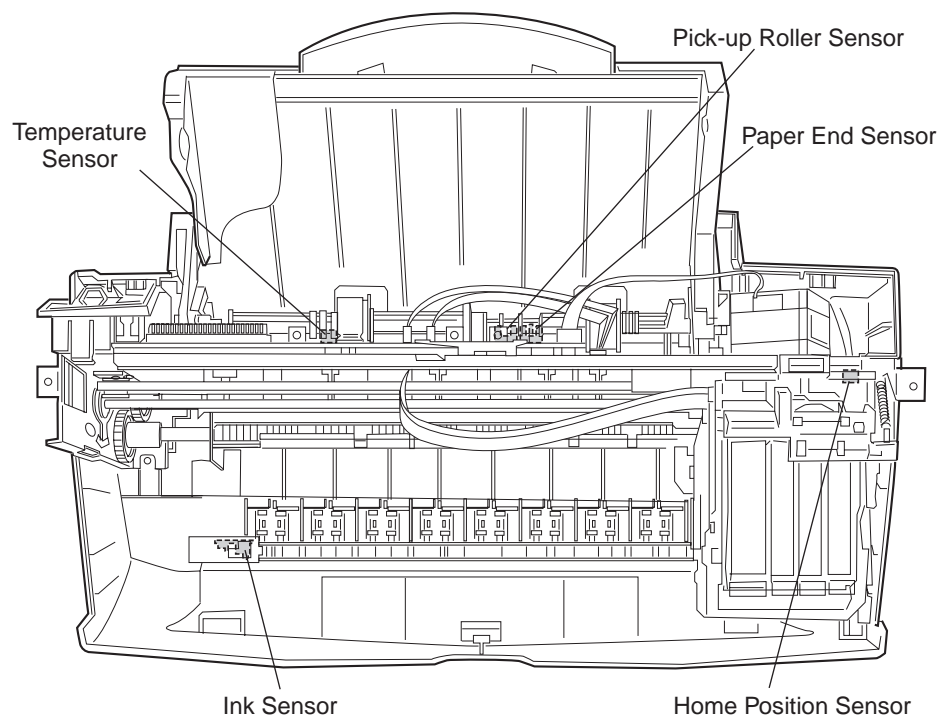

Figure 5-9 Sensor Positions

The home position sensor has two functions: it also operates as the purge sensor to detect the operation of the purge unit.

The home position sensor senses the home position edge and detects the carriage position. After the edge is detected, the carriage moves to the right a specified number of pulses to identify the home position.

Also, at the capping position, it works as a purge sensor and detects the on/off of the purge sensor flag during cleaning operations to recognize the operation of the purge unit.

1.4 About the BJ Cartridge

1.4.1 BJ cartridge structure

The Black BJ cartridge (BC-30) consists of a multi-drop bubble jet head with 160 nozzles in a vertical array. The ink tank is removable from the BJ cartridge. Pigment is used as the ink.

Color/Photo BJ cartridges (BC-33/BC-34Photo) have a multi-drop bubble jet head with a total of 192 nozzles, in 4 colors, with 48 nozzles each, in a vertical array. The ink tanks of each color are removable. The black ink used for the color cartridge is pigment; for the other three colors including PhotoBlack, dyes are used.

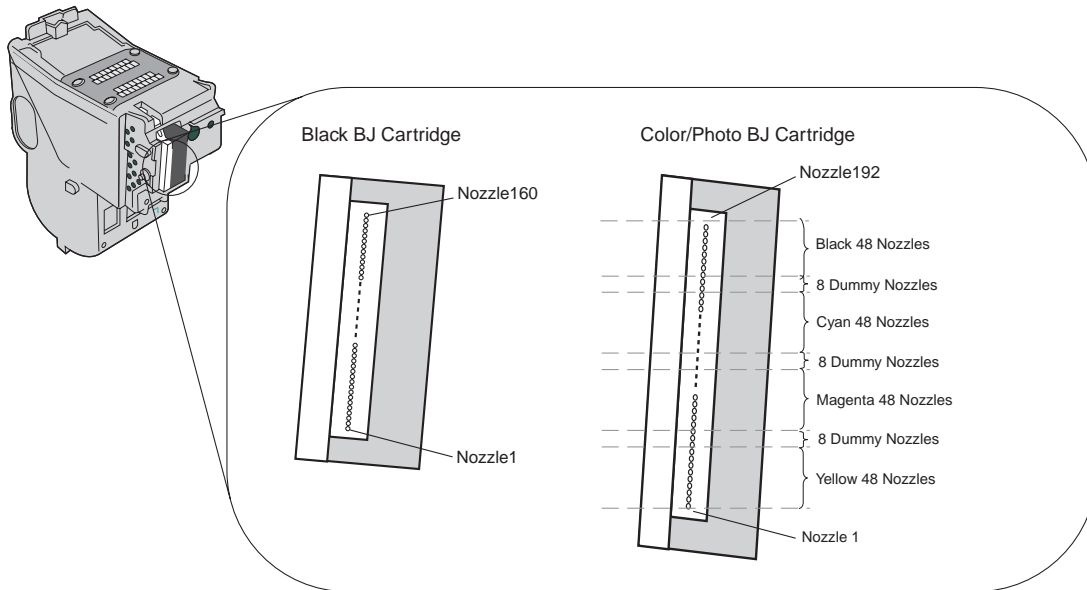

Figure 5-10 Nozzle Arrangement

1.4.2 BJ Cartridge print drive control

The Black BJ cartridge (BC-30) executes the same print drive control as in the BJC-6000.

Color/Photo BJ cartridges, also execute the same print drive control as the Color/Photo BJ cartridges used in the BJC-6000 (BC-31/BC-32Photo: 48 nozzles \times 3 colors, a total of 144 nozzles), although the number of nozzles is different.

1.4.3 BJ cartridge identification

This printer provides the function to detect the both BJ cartridge currently installed and the head rank, using five signals HCLK (pin 13), HDATA (pin 9), HLAT (pin 19), HRESET (pin 29), and DIR (pin28) of the cartridge signal contacts to communicate serially with the bubble jet head unit.

Depending on the heater property variations of the bubble jet head unit generated in manufacturing, all BJ cartridges can be classified into 24 types. The printer performs optimized ink ejection while correcting for the heater property variations.

If the printer is turned on when a BJ cartridge installed in the carriage cannot be correctly identified or when a BJ cartridge is not installed, the carriage automatically moves to the cartridge replacement position, regardless of its previous position.

Also, if the printer is turned on and the cartridge is removed except during replacement, a displaced cartridge error will occur.

1.4.4 List of printing modes

Printing modes when using the Black/Color/Photo BJ cartridges are shown below:

TABLE 5-2 LIST OF PRINTING MODES

Black BJ Cartridge

Printing paper	High speed	Normal (speed)	Normal (Quality)		High-Quality	Highest Quality	Printing Modes
	180x180 (large)	360x360 (large)	360x360 (large)	360x360 (large/small)	720x720 (small)	1440x720 (small)	Resolution (dpi) *1
	2	2	2	4	2	2	Gradation (dot)
Plain paper	1 pass/bi	1 pass/bi	...	2 pass/bi	4 pass/uni	...	*2
Transparencies	...	2 pass/uni	...	4 pass/uni	
BPF	4 pass/uni	
Glossy Paper	4 pass/uni	8 pass/uni	8 pass/uni	
Glossy Film	4 pass/uni	8 pass/uni	...	
High Resolution Paper	...	2 pass/bi	...	4 pass/uni	4 pass/uni	4 pass/uni	
Envelope	...	1 pass/uni	...	4 pass/uni	4 pass/uni	4 pass/uni	

Color BJ Cartridge

Printing paper	High speed	Normal (speed)	Normal (Quality)		High-Quality	Highest Quality	Printing Modes
	180x180 (large)	360x360 (large)	360x360 (large)	360x360 (large/small)	720x720 (small)	1440x720 (small)	Resolution (dpi) *1
	2	2	2	4	2	2	Gradation (dot)
Plain paper	1 pass/bi	1 pass/bi	...	2 pass/bi	4 pass/uni	...	*2
Transparencies	...	2 pass/uni *6	...	4 pass/uni (*3)*6	
BPF	6 pass/uni (*3)*4	
Glossy Paper	4 pass/uni *5	6 pass/uni(8 pass)*5	6 pass/uni(8 pass)*5	
Glossy Film	4 pass/uni *5	6 pass/uni(8 pass)*5	...	
High Resolution Paper	...	2 pass/bi	...	3 pass/uni(4 pass)*5	4 pass/uni*5	4 pass/uni*5	
Envelope	...	1 pass/uni *7	...	3 pass/uni(4 pass)*7	4 pass/uni*7	4 pass/uni*7	

Photo BJ Cartridge

Printing paper	High speed	Normal (speed)	Normal (Quality)		High-Quality	Highest Quality	Printing Modes
	180x180 (large)	360x360 (large)	360x360 (large)	360x360 (large/small)	720x720 (small)	1440x720 (small)	Resolution (dpi) *1
	2	2	2	4	2	2	Gradation (dot)
Plain Paper	3 pass/uni *6	...	*2
High Resolution Paper	3 pass/uni *6	...	
Glossy Paper	4 pass/uni *6	...	
Envelope	3 pass/uni *6	...	

- *1: (large): printed in large drops; (small): printed in small drops; (large and small): printed in both large and small drops
- *2: number of print passes/printing direction; bi: bi-directional; uni: unidirectional; if the number of print passes differ when in the gray scale mode, print passes are indicated in ().
- *3: Printed in extra large mode
- *4: Composite black is used to print in black
- *5: Same as the above, except in the gray scale mode, only black ink is used.
- *6: Both black ink and composite black are used to print in black. Generally, dark black is printed in black ink, and light black (gray) is printed in composite black. Gradation from dark black to white is realized by adjusting the ratio of black ink and composite black.
- *7: Same as the above, except in the gray scale mode, only black ink is used.



1.5 About the Scanner Cartridge

The scanner cartridge is a replaceable scanner unit. It carries a one-line 256 pixel CCD, and by scanning the same line three times, switching each of the three RGB primary colors of the LED, it separates one line of the color image into three RGB colors, output in 8-bit signals (256 gradation in each RGB color). For a monochrome image, the image is output either as an 8-bit or 1-bit signal by lighting the green (G) LED and scanning once.

1.5.1 Scanner block diagram and the data flow

When scanning, the light source LED lights up and illuminates the document on the platen. Reflected light rays pass through the field lens and the imaging lens, and are converged onto the CCD. The CCD converts the converged light rays to analog signals, which are then converted to digital signals by the scanner controller, and the scanned image is processed. The image data is then passed through the scanner cartridge's I/F controller to the printer. The printer then sends the image data to the computer through the USB interface or the Centronics interface. Data in each line of the image will be transferred per RGB color; therefore, three transfers are executed per line of data.

Operations within the scanner block are shown below in order of data processing:

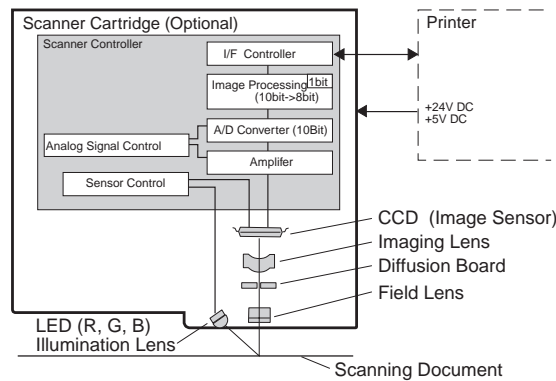

Figure 5-11 Scanner Block Diagram

1) LED Illumination Lens

LED illumination lens consists of the light source LED and the illumination lens. The LED part uses red, green and blue LEDs as light sources to illuminate the scanning document. Only the green LED is used for monochrome scanning. The illumination lens part is a "D" shaped lens which converges the light from the LED light source.

2) Field Lens

This lens prevents magnification/reduction caused by changes in the head to paper gap when scanning a folded or bent document.

3) Diffusion Board

The light intensity of the LED is brighter at the center than at the edges. The diffusion board allows even distribution of light from the document.

4) Imaging Lens

This lens is used for forming an image of the light rays converged by the field lens onto the CCD.

5) CCD

The scanner cartridge uses a semiconductor type image sensor, one-line 256 pixel CCD (Charge Coupled Device). Depending on the light amount of the image formed on the CCD, voltage signals are sent to the scanner controller as image signals.

6) Scanner Controller

The scanner controller is an IC that processes the analog signals into digital images.

a) Sensor Control

The sensor control controls the LED and the CCD.

b) Amplifier

The amplifier amplifies the analog input from the CDD.

c) Analog Signal Control

This unit performs offset correction for the amplified analog input, black-level correction which sets the maximum value to black, etc. on. It also provides the standard power to the A/D converter.

d) A/D Converter

The A/D Converter converts the analog input, corrected, in the analog signal control unit to digital 10-bit image data.

e) Image Processing

Image processing unit executes shading correction (variation in image density between each line in the feeding direction of paper may occur due to the variation of the sensitivities of the CCD sensor elements and the uneven distribution of light transmitted through the center and the periphery of the lenses; the scanned data is compared against a calibration data based on the white calibration sheet to even out and the density is corrected). It also converts the 10-bit data transmitted from the A/D converter to 8-bit (256-gradation) data, converts the output resolution, and carries out the edge emphasis function. It has a 1-bit (2-gradation) image procession function and built-in SRAM used for output buffer memory.

f) I/F Controller

The I/F controller controls the serial interface between the scanner cartridge in the carriage and the printer unit. Two types of transfer clock, 4MHz and 2MHz, are supported for the data transfer between the scanner and the printer.

1.5.2 Scan modes**TABLE 5-3 SCAN MODES**

Scanning resolution (H×V)	Scanning Image Pixel Width			Carriage Speed (inch/sec)	Transfer Clock from Scanner to Printer
	Color	Black & White			
	Color (8bit)	Gray Scale (8bit)	Mono (1bit)		
720 × 720	96*, 128*, 160*	256*	256	Approx. 4.1	4 MHz
360 × 360	256*	256*	256	Approx. 10.0	4 MHz
300 × 360	256*	256*	256	Approx. 10.0	4 MHz
200 × 180	256*	256*	256	Approx. 16.6	2 MHz
180 × 180	256*	256*	256	Approx. 20.0	2 MHz
90 × 90	256*	256*	256	Approx. 28.0	2 MHz

*: Two-pass scanning is performed by feeding a paper for half the pixel width of the scanning image. The scanning resolution is improved by scanning the same line twice to balance out the image.

When scanning at 720 × 720dpi, the scanning image pixel width is automatically adjusted, depending on the paper width, for the direction of the carriage. The longer the paper width direction, the smaller the scanning pixel width.

1.5.3 Image gradation and bit data size

Refer to the description below for the relationships between the image gradation and the bit data size.

a) 256-gradation/8-bit data/multi-value

256-gradation is processed by 8-bit data. Within the scanner, the image processing unit in the scanner controller normally processes the 8 bit data. 256-gradation can also be referred to as the multi-value.

b) 2-gradation/1-bit data/2-value

2-gradation (monochrome) is processed by 1-bit data. Within the scanner, the image controller unit in the scanner controller processes the data in 2-gradation. When the monochrome processing is selected, data with 256-gradation will be processed as 2-gradation data in monochrome by the prescribed threshold value after the normal processing of 8-bit data is completed.

1.5.4 Scanner cartridge detection

The scanner cartridge detection within the printer is performed by DIA, DIK, and SCHKR. The internal register setting within the scanner cartridge between DIA and DIK is 5.6K ohms, and between DIK and SCHKR is 22K ohms.

1.5.5 Calibration operation based on the white calibration sheet

In the calibration process, data such as the printer's internal temperature, black level data, and white standard data are sampled to be used as a reference in scanning, to create the calibration data.

The scanner driver on the host computer retains the past 5 calibration data samples and saves them in a file.

When a scanner operation is performed, a value from the compiled temperature data that is within $\pm 5^{\circ}\text{C}$ of the printer's internal temperature at present is downloaded to the scanner controller.

The scanner driver requests calibration when there is no compiled data within $\pm 5^{\circ}\text{C}$.

1.5.6 Scanning time and data size (reference)

The scanning time and scanning data sizes are listed below.

When the scanning data sizes are stored into the files, the scanning data sizes are varied with the file format.

Measurement Conditions

- Host computer: DELL XPS T550 (Pentium III 550MHz, internal memory 256MB)
- Interface: Parallel interface, ECP mode
- Paper size: A4
- Scan time: from the start of the paper feed operation to ejection

TABLE 5-4 SCANNING TIME AND DATA SIZE (REFERENCE)

Scanning resolution (HxV)	Scanning Modes		
	Color	Black & White	
	Color	Gray Scale (8bit)	Mono (1bit)
720 × 720	Approx. 25Min.08Sec. 137261 KByte	Approx. 6Min.57Sec. 45753 KByte	Approx. 3Min.05Sec. 5719 KByte
360 × 360	Approx. 6Min.39Sec. 34315 KByte	Approx. 1Min.41Sec. 11438 KByte	Approx. 50Sec. 992 KByte
180 × 180	Approx. 3Min.16Sec. 8576 KByte	Approx. 1Min.09Sec. 2858 KByte	Approx. 32Sec. 357 KByte
90 × 90	Approx. 3Min.09Sec. 2143 KByte	Approx. 1Min.03Sec. 714 KByte	Approx. 27Sec. 91 KByte

2. CONNECTORS AND PIN LAYOUT

2.1 Control Board

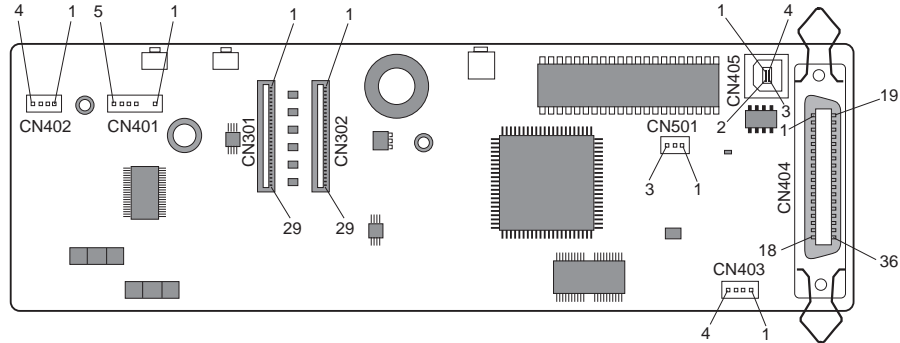

Figure 5-12 Control Board

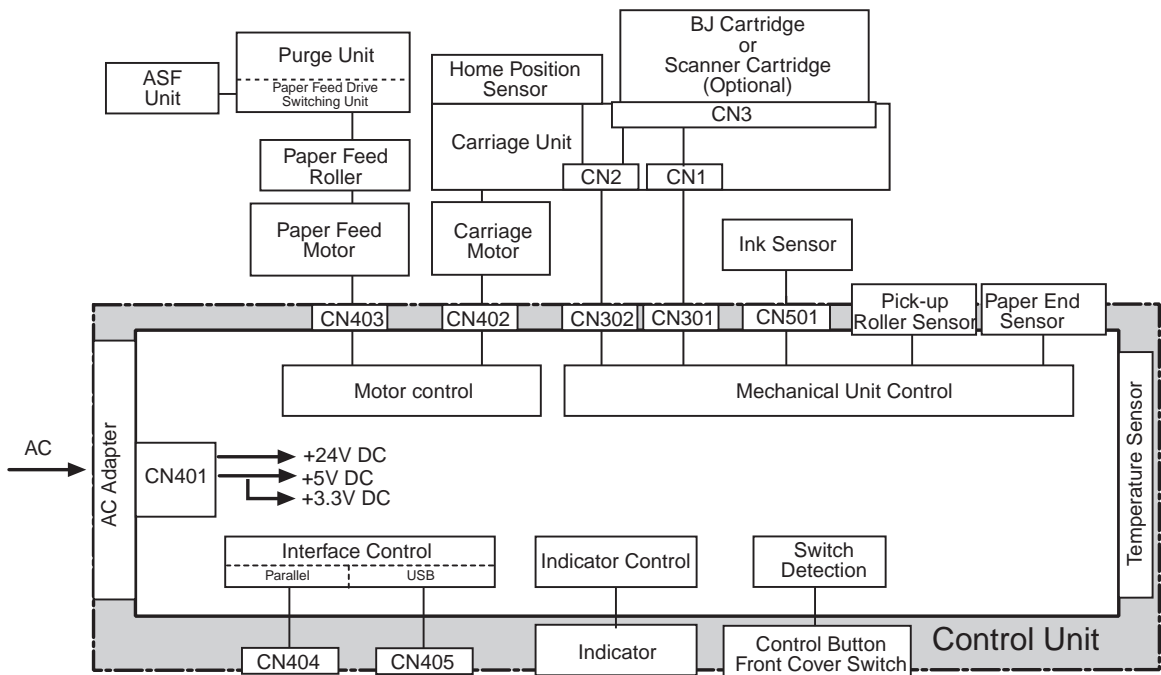

Figure 5-13 Printer Diagram

Appendix

CN404 (Parallel Interface Connector)

Pin No.	Compatible Mode	Nibble Mode	ECP Mode
1	STROBE	HostClk	HostClk
2	DATA1	Data1	Data1
3	DATA2	Data2	Data2
4	DATA3	Data3	Data3
5	DATA4	Data4	Data4
6	DATA5	Data5	Data5
7	DATA6	Data6	Data6
8	DATA7	Data7	Data7
9	DATA8	Data8	Data8
10	ACKNLG	PrtClk	PeriphClk
11	BUSY	PrtBusy	PeriphAck
12	P.E.	AckDataReq	AckReverse
13	SELECT	Xflag	Xflag
14	AUTO FEED XT	HostBusy	HostAck
15	N.C.	Undefined	Undefined
16	GND	Gnd	Gnd
17	GND	Gnd	Gnd
18	+5.0V	Vcc	Vcc
19	STROBE-RET (GND)	Signal Gnd	Signal Gnd
20	DATA1-RET (GND)	Signal Gnd	Signal Gnd
21	DATA2-RET (GND)	Signal Gnd	Signal Gnd
22	DATA3-RET (GND)	Signal Gnd	Signal Gnd
23	DATA4-RET (GND)	Signal Gnd	Signal Gnd
24	DATA5-RET (GND)	Signal Gnd	Signal Gnd
25	DATA6-RET (GND)	Signal Gnd	Signal Gnd
26	DATA7-RET (GND)	Signal Gnd	Signal Gnd
27	DATA8-RET (GND)	Signal Gnd	Signal Gnd
28	ACKNLG-RET (GND)	Signal Gnd	Signal Gnd
29	BUSY-RET (GND)	Signal Gnd	Signal Gnd
30	P.E.-RET (GND)	Signal Gnd	Signal Gnd
31	INIT	INIT	ReverseReq
32	ERROR	DataAvail	PeriphReq
33	GND	Undefined	Undefined
34	N.C.	Undefined	Undefined
35	+5.0V	Undefined	Undefined
36	SELECT IN	1284Active	1284Active

CN405 (USB Interface Connector)

Pin No.	Signal Name	IN/OUT	Function
1	PWR	IN	Cable power supply
2	D -		Data
3	D +		Data
4	GND	...	Cable GND

CN401 (DC Power Connector)

Pin No.	Signal Name	IN/OUT	Function
1	+24V	IN	+24V DC
2	Not used
3	HGND	...	GND
4	+5V-GND	...	GND
5	+5V	IN	+5VDC

CN402 (Carriage Motor Connector)

Pin No.	Signal Name	IN/OUT	Function
1	CRA	OUT	Carriage Motor Phase A
2	CRB	OUT	Carriage Motor Phase B
3	$\overline{\text{CRA}}$	OUT	Carriage Motor Phase $\overline{\text{A}}$
4	$\overline{\text{CRB}}$	OUT	Carriage Motor Phase $\overline{\text{B}}$

CN403 (Paper Feed Motor Connector)

Pin No.	Signal Name	IN/OUT	Function
1	LFA	OUT	Paper Feed Motor Phase A
2	LFB	OUT	Paper Feed Motor Phase B
3	$\overline{\text{LFA}}$	OUT	Paper Feed Motor Phase $\overline{\text{A}}$
4	$\overline{\text{LFB}}$	OUT	Paper Feed Motor Phase $\overline{\text{B}}$

CN501 (Ink Sensor Connector)

Pin No.	Signal Name	IN/OUT	Function
1	PWM1	OUT	Ink sensor's photo LED drive signal.
2	GND
3	INKS	IN	Voltage value varied by the amount of reflected light

CN301 (Carriage Ribbon Cable Connector) / Carriage Board : CN1

CN301 Pin No.	Signal Name	IN/OUT	Function	CN1 Pin No.
1~12	HVH	OUT	Head heater drive voltage VH	18~29
13~15	SUBHO	OUT	Sub heater drive voltage	15~17
16~27	GND	3~14
28, 29	HVDD	OUT	Head's logic voltage	1, 2

CN302 (Carriage Ribbon Cable Connector) / Carriage board : CN2

CN302 Pin No.	Signal Name	IN/OUT	Function	CN2 Pin No.
1	HDATA	IN/OUT	Serial data transferred by clock signal	29
2	GND	28
3	HCLOCK	IN/OUT	Clock data that transfers serial data	27
4	GND	26
5	HSEL1B	OUT	Higher 1 to 8, 17 to 24, ..., 177 to 184 within the head block Front nozzle heater selection signal (1 to 8, 17 to 24, ..., 145 to 152)*	25
6	HSEL1A	OUT	Higher 1 to 8, 17 to 24, ..., 177 to 184 within the head block Rear nozzle heater selection signal (1 to 8, 17 to 24, ..., 145 to 152)*	24
7	HSEL2B	OUT	Lower 9 to 16, 25 to 32, ..., 185 to 192 within the head block Front nozzle heater selection signal (9 to 16, 25 to 32, ..., 153 to 160)*	23
8	HSEL2A	OUT	Lower 9 to 16, 25 to 32, ..., 185 to 192 within the head block Rear nozzle heater selection signal (9 to 16, 25 to 32, ..., 153 to 160)*	22
9	ODD	OUT	Heater selection signal for odd nozzle within the head block	21
10	GND	20
11	HALT	OUT	Timing signal that latches serial data	19
12	GND	18
13	BENB0 **	OUT	Signal to generate output signal for heater enable decoder	17
14	EVEN	OUT	Heater selection signal for even nozzle within the head block	16
15	HENB0	OUT	Rear heater drive signal for 1 to 168 (1 to 112)* nozzles within the head	15
16	BENB1 **	OUT	Signal to generate output signal for heater enable decoder	14
17	HENB2	OUT	Rear heater drive signal for 169 to 192 (113 to 160)* nozzles within the head	13
18	HENB1	OUT	Front heater drive signal for 1 to 168 (1 to 112)* nozzles within the head	12
19	DIR	OUT	Control signal for serial data input/output direction	11
20	HENB3	OUT	Front heater drive signal for 169 to 192 (113 to 160)* nozzles within the head	10
21	GND	9
22	HRESET	OUT	Reset signal	8
23	DIA	OUT	Head temperature sensor (diode) anode	7
24	DIK	IN	Head temperature sensor (diode) cathode	6
25~27	GND	3~5
28	HPA	OUT	Home position sensor signal pull-up voltage	2
29	HPC	IN	Home position sense signal	1

* : The applicable nozzle varies when using the Black BJ cartridge. Indicated in the ().

** : Details of BENB0 and BENB1.

BENB0	BENB1	Applicable nozzle
Low	Low	1, 2, 9, 10, ..., 153, 154, ..., 186, 187 (1+8n, 2+8n : n=0~23)
High	Low	3, 4, 11, 12, ..., 155, 156, ..., 187, 188 (3+8n, 4+8n : n=0~23)
Low	High	5, 6, 13, 14, ..., 157, 158, ..., 189, 190 (5+8n, 6+8n : n=0~23)
High	High	7, 8, 15, 16, ..., 159, 160, ..., 191, 192 (7+8n, 8+8n : n=0~23)

2.2 Carriage Board

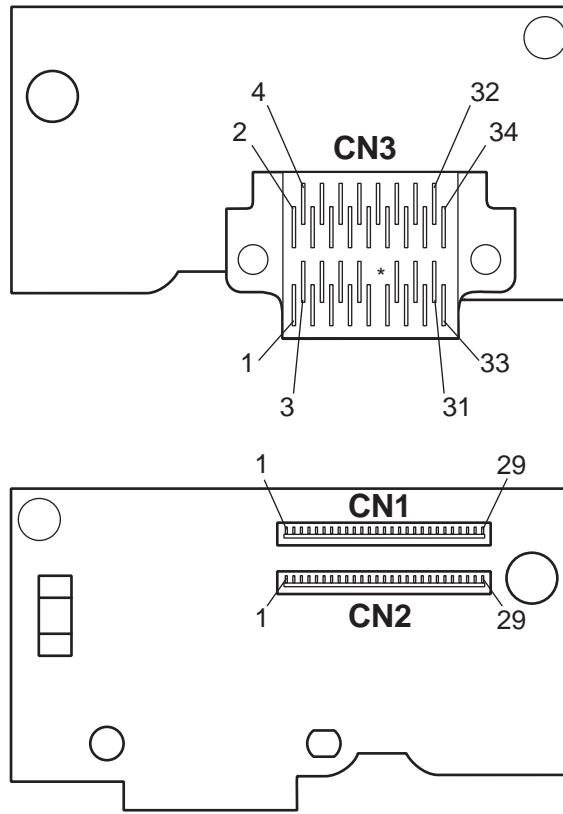

Figure 5-14 Carriage Board

CN1 (Carriage Ribbon Cable Connector)

Refer to Page 5-18 (Description of the Carriage Ribbon Cable Pins for CN301)

CN2 (Carriage Ribbon Cable Connector)

Refer to Page 5-18 (Description of the Carriage Ribbon Cable Pins for CN302)

CN3 (Cartridge)

Pin No.	Signal Name	IN/OUT	Function
1~32			Refer to Page 5-20 (Description of the BJ Cartridge Pins)
33, 34	N.C.

2.3 BJ Cartridge

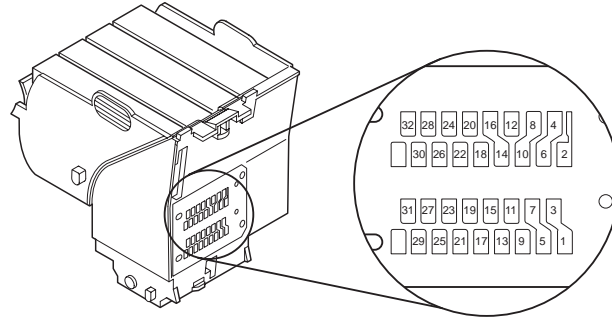

Figure 5-15 BJ Cartridge

Pin No	Signal Name	IN/OUT	Function
1, 2, 3	HVH	OUT	Head heater drive voltage VH +24V
4, 6	SUBH	OUT	Sub heater drive signal
5, 7, 8, 10	VHG	...	Head drive voltage VHGND
9	HDATA		Serial data transferred by clock signal (H_CLK) Head identification data and rank resistance detection value inclusive
11	HSEL1B	OUT	Higher 1 to 8, 17 to 24, ..., 177 to 184 within the head block Rear nozzle heater selection signal (1 to 8, 17 to 24, ..., 145 to 152)*
12	HVDD	OUT	Head's logic drive voltage +5V
13	HCLK		Clock data that transfers serial data
14, 16	GND	OUT	Head's logic drive voltage HVDD GND
15	HSEL1A	OUT	Higher 1 to 8, 17 to 24, ..., 177 to 184 within the head block Front nozzle heater selection signal (1 to 8, 17 to 24, ..., 145 to 152)*
17	HSEL2A	OUT	Lower 9 to 16, 25 to 32, ..., 185 to 192 within the head block Front nozzle heater selection signal (9 to 16, 25 to 32, ..., 153 to 160)*
18	HSEL2B	OUT	Lower 9 to 16, 25 to 32, ..., 185 to 192 within the head block Rear nozzle heater selection signal (9 to 16, 25 to 32, ..., 153 to 160)*
19	HLAT	OUT	Timing signal that latches serial data
20	ODD	OUT	Heater selection signal for odd nozzle within the head block
21	EVEN	OUT	Heater selection signal for even nozzle within the head block
22	BENB0 **	OUT	Signal to generate output signal for heater enable decoder
23	BENB1 **	OUT	Signal to generate output signal for heater enable decoder
24	HENB0	OUT	Rear heater drive signal for 1 to 168 (1 to 112)* nozzles within the head
25	HENB1	OUT	Front heater drive signal for 1 to 168 (1 to 112)* nozzles within the head
26	HENB2	OUT	Rear heater drive signal for 169 to 192 (113 to 160)* nozzles within the head
27	HENB3	OUT	Front heater drive signal for 169 to 192 (113 to 160)* nozzles within the head
28	DIR	OUT	Control signal for serial data input/output direction
29	HRESET	OUT	Reset signal
30	DIA0 (DIA1)	OUT	Head temperature sensor (diode) anode
31	DIK0 (DIK1)	OUT	Head temperature sensor (diode) cathode
32	Not used

* : The applicable nozzle varies when using the black BJ cartridge. Indicated in the ().

** : Details of BENB0 and BENB1.

BENB0	BENB1	Applicable nozzle
Low	Low	1, 2, 9, 10, ..., 153, 154, ..., 186, 187 (1+8n, 2+8n : n=0~23)
High	Low	3, 4, 11, 12, ..., 155, 156, ..., 187, 188 (3+8n, 4+8n : n=0~23)
Low	High	5, 6, 13, 14, ..., 157, 158, ..., 189, 190 (5+8n, 6+8n : n=0~23)
High	High	7, 8, 15, 16, ..., 159, 160, ..., 191, 192 (7+8n, 8+8n : n=0~23)

2.4 Scanner Cartridge (Optional)

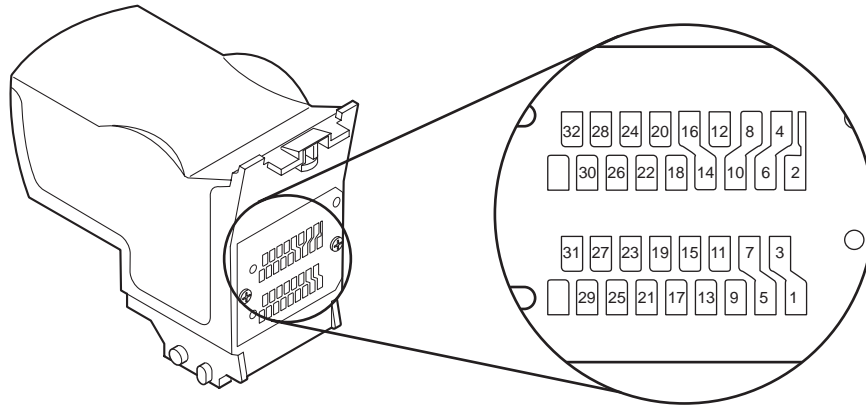

Figure 5-16 Scanner Cartridge

Pin No.	Signal Name	IN/OUT	Function
1, 2, 3	VHLED	IN	+24V, for LED
4	N.C.	...	Not used
5	GNDLED	...	GND
6	N.C.	...	Not used
7, 8	GNDLED	...	GND
9	DT0	IN/OUT	Serial data of scanned images
10	GNDLED	...	GND
11	RWR	IN	Right clock for internal register setting
12	VDD	IN	+5V
13	DTCK	IN/OUT	Serial data clock of scanned images
14	VSS	...	GND
15	REN	IN	Enable signal for internal register setting
16	VSS	...	GND
17	RDT	IN	Internal register setup data
18	SCHKR	IN	Scanner cartridge detection and recognition
19	LNST	IN	Scan start signal (1 line scan)
20, 21, 22	N.C.	IN	Not used
23	DT1	IN	Factory
24	DT2	IN	Factory
25	DT3	IN	Factory
26, 27, 28	N.C.	IN	Not used
29	RST	IN	Reset
30	DIA	OUT	Scanner cartridge detection and recognition
31	DIK	OUT	Scanner cartridge detection and recognition
32	Not used

2.5 AC Adapter

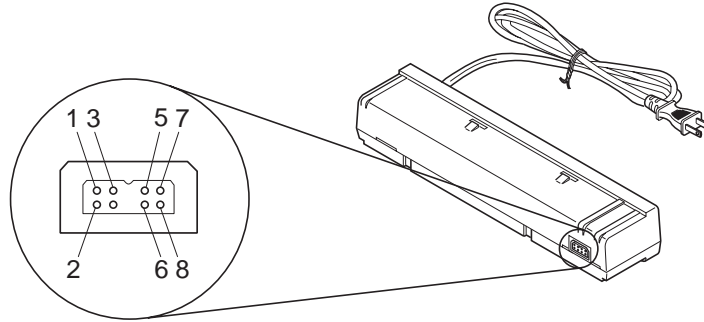

Figure 5-17 AC Adapter

Pin No.	Signal Name	IN/OUT	Function
1	N.C.
2	N.C.
3	+24V	...	+24V DC
4	N.C.
5	+5V	OUT	+5V DC
6	+5-GND	...	GND
7	N.C.
8	HGND	...	GND

2.6 DC Power Supply Cable

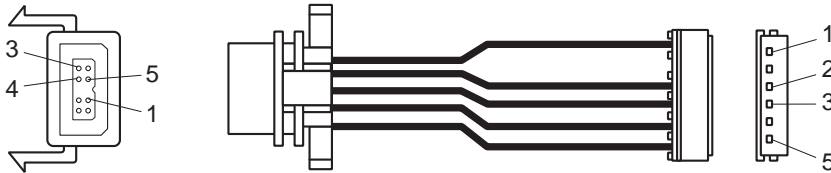

Figure 5-18 DC Power Supply Cable

Pin No.	Signal Name	IN/OUT	Function
1	+24V	OUT	+24V DC
2
3	HGND	...	GND
4	+5V-GND	...	GND
5	+5V	OUT	+5V DC

2.7 Carriage Motor

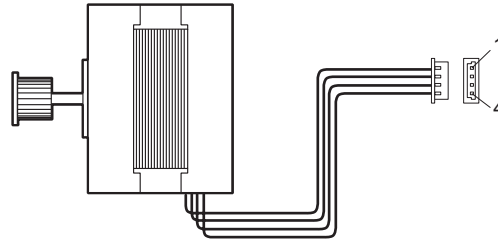

Figure 5-19 Carriage Motor

Pin No.	Signal Name	IN/OUT	Function
1	CRA	IN	Carriage Motor Phase A
2	CRB	IN	Carriage Motor Phase B
3	$\overline{\text{CRA}}$	IN	Carriage Motor Phase $\overline{\text{A}}$
4	$\overline{\text{CRB}}$	IN	Carriage Motor Phase $\overline{\text{B}}$

2.8 Paper Feed Motor

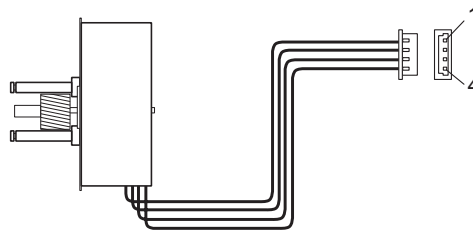

Figure 5-20 Paper Feed Motor

Pin No.	Signal Name	IN/OUT	Function
1	LFA	IN	Paper Feed Motor Phase A
2	LFB	IN	Paper Feed Motor Phase B
3	$\overline{\text{LFA}}$	IN	Paper Feed Motor Phase $\overline{\text{A}}$
4	$\overline{\text{LFB}}$	IN	Paper Feed Motor Phase $\overline{\text{B}}$

2.9 Ink Sensor

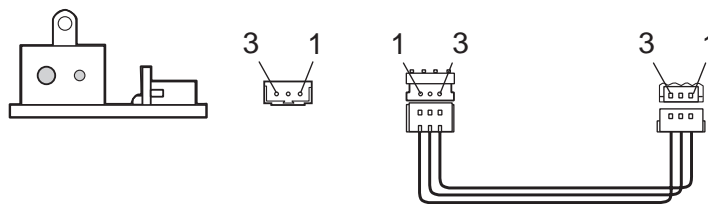
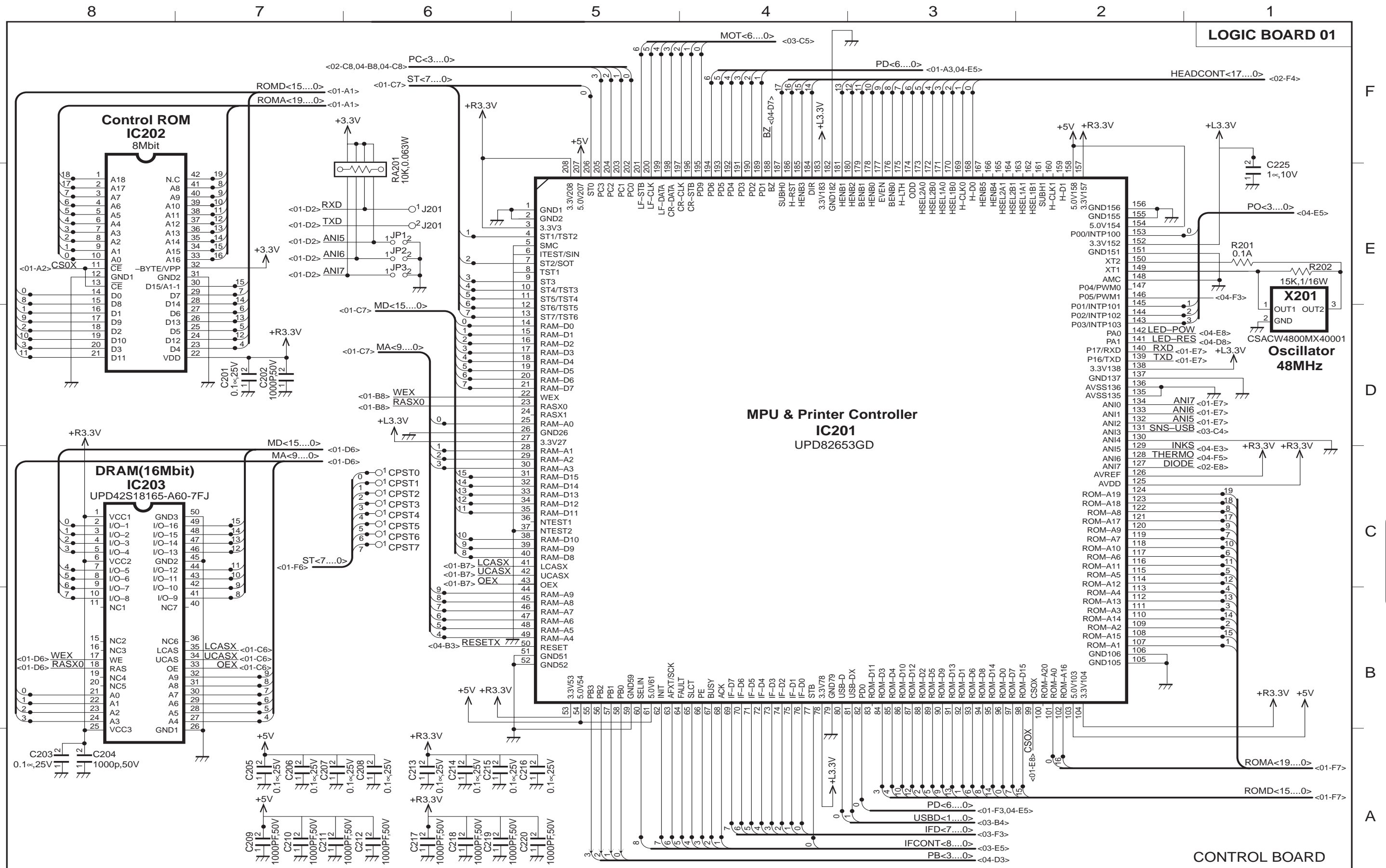

Figure 5-21 Ink Sensor

Pin No.	Signal Name	IN/OUT	Function
1	PWM1	IN	Ink sensor's photo LED drive voltage
2	GND
3	INKS	OUT	Voltage value varied by the amount of reflected light

This page intentionally left blank.

2.10 Circuit Diagrams



F
E
D
C
B
A

Appendix

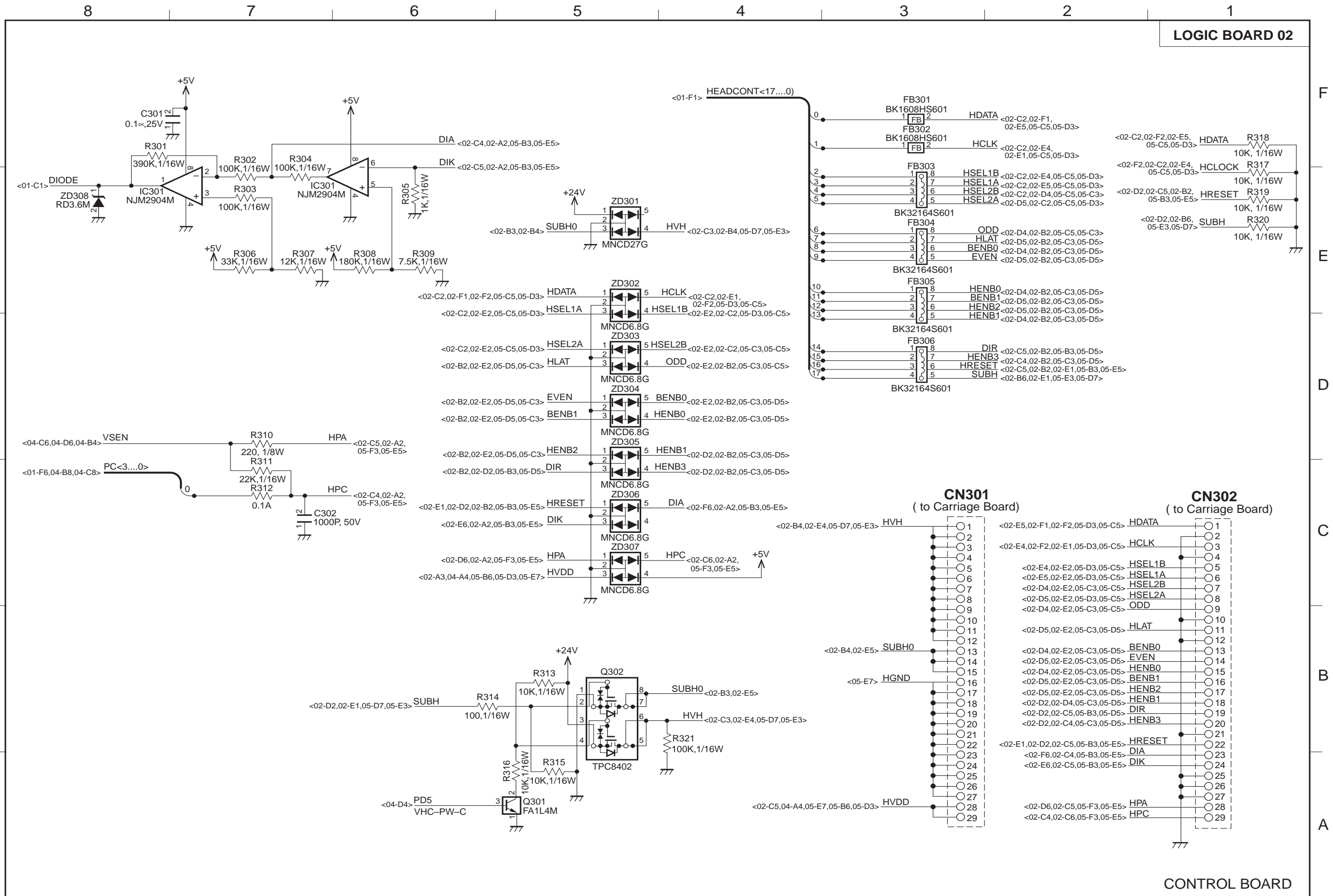

Appendix

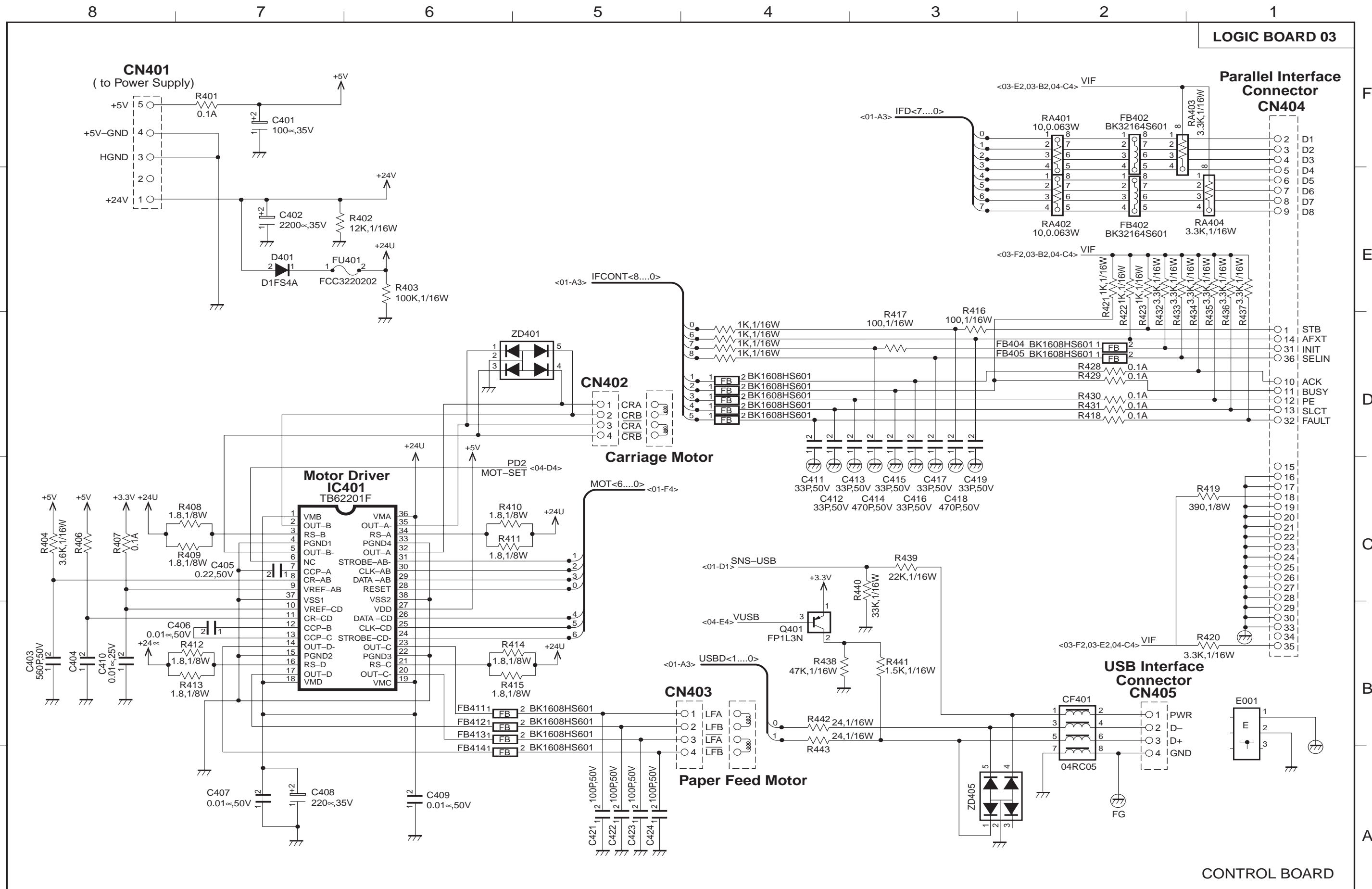

Appendix

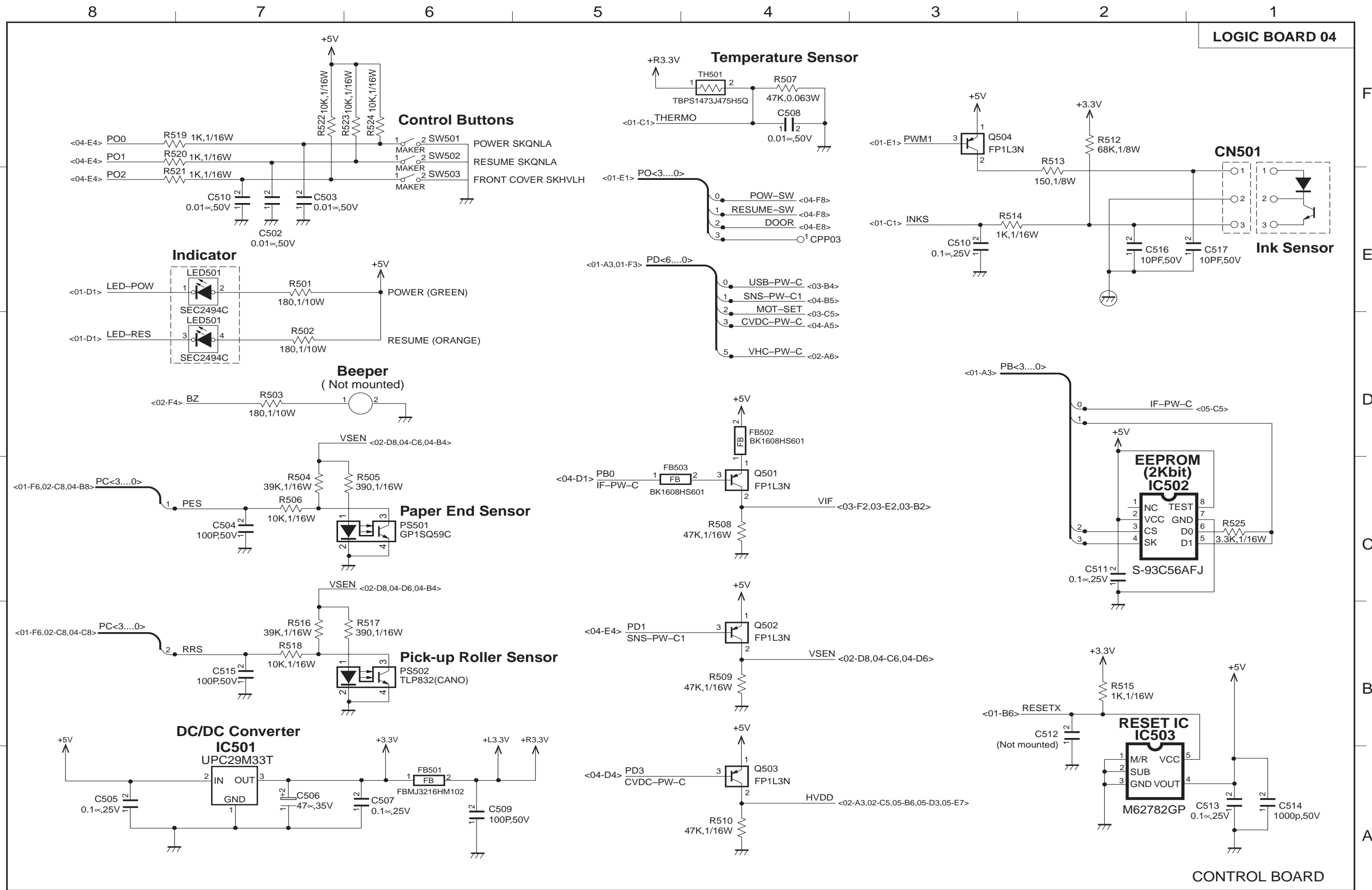

F
E
D
C
B
A

Appendix

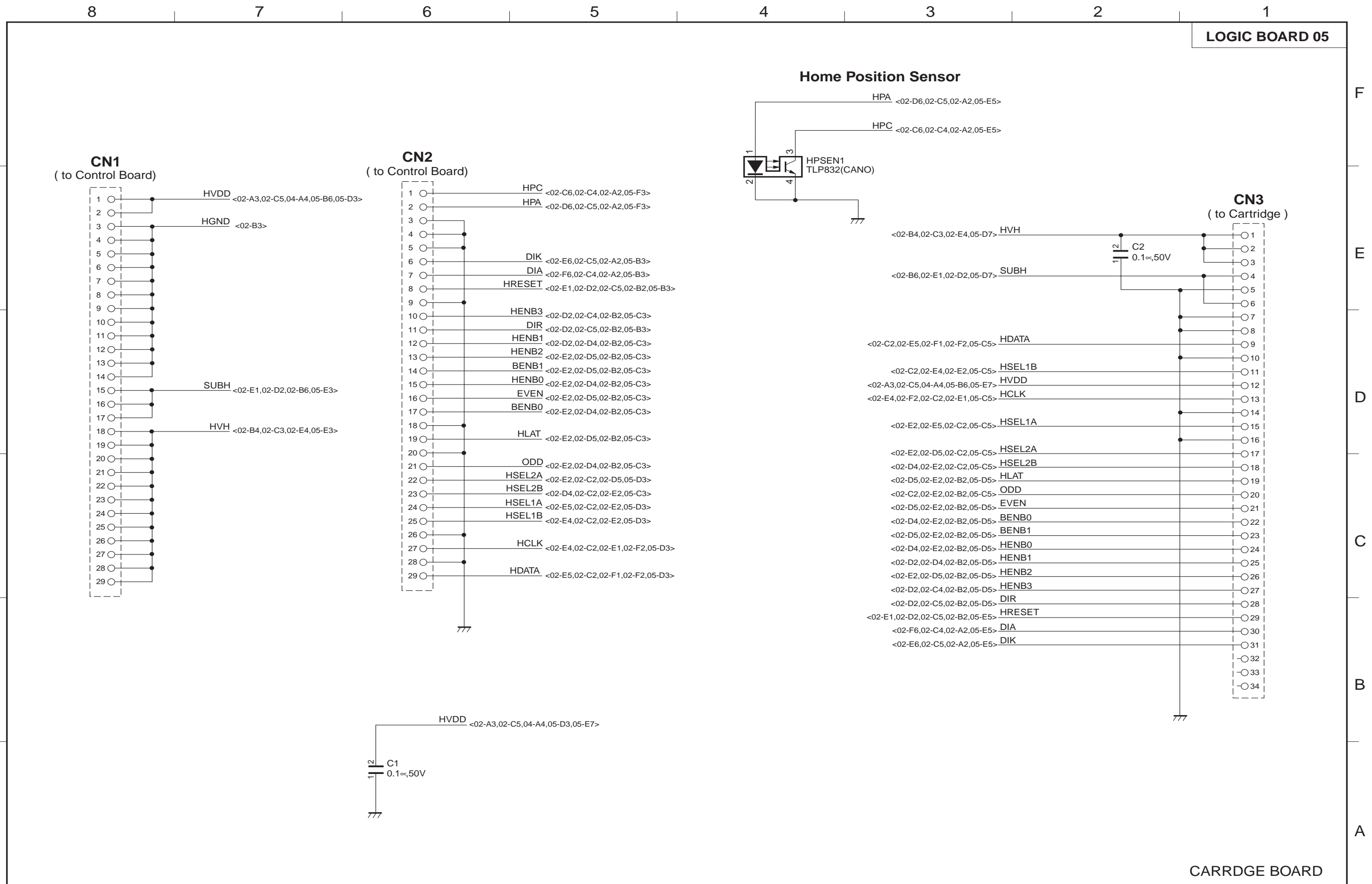

Appendix



The printing paper contains
70% waste paper.

Canon